

Reactive Power Compensation Technologies: State-of-the-Art Review

JUAN DIXON, SENIOR MEMBER, IEEE, LUIS MORÁN, FELLOW, IEEE,
JOSÉ RODRÍGUEZ, SENIOR MEMBER, IEEE, AND RICARDO DOMKE

Invited Paper

This paper presents an overview of the state of the art in reactive power compensation technologies. The principles of operation, design characteristics and application examples of Var compensators implemented with thyristors and self-commutated converters are presented. Static Var generators are used to improve voltage regulation, stability, and power factor in ac transmission and distribution systems. Examples obtained from relevant applications describing the use of reactive power compensators implemented with new static Var technologies are also described.

Keywords—Reactive power, static Var compensators (SVCs).

I. INTRODUCTION

Var compensation is defined as the management of reactive power to improve the performance of ac power systems. The concept of Var compensation embraces a wide and diverse field of both system and customer problems, especially related with power quality issues, since most power quality problems can be attenuated or solved with an adequate control of reactive power [1]. In general, the problem of reactive power compensation is viewed from two aspects: load compensation and voltage support. In load compensation the objectives are to increase the value of the system power factor, to balance the real power drawn from the ac supply, to compensate voltage regulation, and to eliminate current harmonic components produced by large

and fluctuating nonlinear industrial loads [2], [3]. Voltage support is generally required to reduce voltage fluctuation at a given terminal of a transmission line. Reactive power compensation in transmission systems also improves the stability of the ac system by increasing the maximum active power that can be transmitted. It also helps to maintain a substantially flat voltage profile at all levels of power transmission, it improves high-voltage dc (HVDC) conversion terminal performance, increases transmission efficiency, controls steady-state and temporary overvoltages [4], and can avoid disastrous blackouts [5], [6].

Series and shunt Var compensation are used to modify the natural electrical characteristics of ac power systems. Series compensation modifies the transmission or distribution system parameters, while shunt compensation changes the equivalent impedance of the load [1], [7]. In both cases, the reactive power that flows through the system can be effectively controlled improving the performance of the overall ac power system.

Traditionally, rotating synchronous condensers and fixed or mechanically switched capacitors or inductors have been used for reactive power compensation. However, in recent years, static Var compensators (SVCs) employing thyristor-switched capacitors (TSCs) and thyristor-controlled reactors (TCRs) to provide or absorb the required reactive power have been developed [7]–[9]. Also, the use of self-commutated pulsewidth modulation (PWM) converters with an appropriate control scheme permits the implementation of static compensators capable of generating or absorbing reactive current components with a time response faster than the fundamental power network cycle [10]–[12].

Based on the use of reliable high-speed power electronics, powerful analytical tools, advanced control and micro-computer technologies, flexible ac transmission systems (FACTS) have been developed and represent a new concept for the operation of power transmission systems [13], [14]. In these systems, the use of SVCs with fast response times

Manuscript received August 15, 2005; revised October 6, 2005. This work was supported in part by Fondecyt (the Chilean Research Council) under Project 1050067 and in part by the Universidad Federico Santa María.

J. Dixon is with the Electrical Engineering Department, Pontificia Universidad Católica de Chile, Santiago 690441, Chile (e-mail: jdixon@ing.puc.cl).

L. Morán and R. Domke are with the Electrical Engineering Department, Universidad de Concepción, Concepción, Chile (e-mail: l Moran@udec.cl).

J. Rodríguez is with the Electronic Engineering Department, Universidad Federico Sta. María, Valparaíso, Chile (e-mail: jrp@elo.utfsm.cl).

Digital Object Identifier 10.1109/JPROC.2005.859937

0018-9219/\$20.00 © 2005 IEEE

play an important role, allowing to increase the amount of apparent power transfer through an existing line, close to its thermal capacity, without compromising its stability limits. These opportunities arise through the ability of special SVCs to adjust the interrelated parameters that govern the operation of transmission systems, including shunt impedance, current, voltage, phase angle and the damping of oscillations [15].

This paper presents an overview of the state of the art of static Var technologies. Static compensators implemented with thyristors and self-commutated converters are described. Their principles of operation, compensation characteristics and performance are presented and analyzed. A comparison of different Var generator compensation characteristics, is also presented. New static compensators such as unified power flow controllers (UPFCs) and dynamic voltage restorers (DVRs), required to compensate modern power distribution systems, are also presented and described [28].

II. REACTIVE POWER COMPENSATION PRINCIPLES

In a linear circuit, the reactive power is defined as the ac component of the instantaneous power, with a frequency equal to 100/120 Hz in a 50- or 60-Hz system. The reactive power generated by the ac power source is stored in a capacitor or a reactor during a quarter of a cycle, and in the next quarter cycle is sent back to the power source. In other words, the reactive power oscillates between the ac source and the capacitor or reactor, and also between them, at a frequency equals to two times the rated value (50 or 60 Hz). For this reason it can be compensated using Var generators, avoiding its circulation between the load (inductive or capacitive) and the source, and therefore improving voltage stability of the power system. Reactive power compensation can be implemented with Var generators connected in parallel or in series.

The principles of both shunt and series reactive power compensation alternatives are described below.

A. Shunt Compensation

Fig. 1 shows the principles and theoretical effects of shunt reactive power compensation in a basic ac system, which comprises a source V_1 , a power line, and a typical inductive load. Fig. 1(a) shows the system without compensation and its associated phasor diagram. In the phasor diagram, the phase angle of the current has been related to the load side, which means that the active current I_P is in phase with the load voltage V_2 . Since the load is assumed inductive, it requires reactive power for proper operation and hence, the source must supply it, increasing the current from the generator and through power lines. If reactive power is supplied near the load, the line current can be reduced or minimized, reducing power losses and improving voltage regulation at the load terminals. This can be done in three ways: 1) with a capacitor; 2) with a voltage source; or 3) with a current source. In Fig. 1(b), a current-source device is being used to compensate the reactive component of the load current (I_Q). As a result, the system voltage regulation is improved and

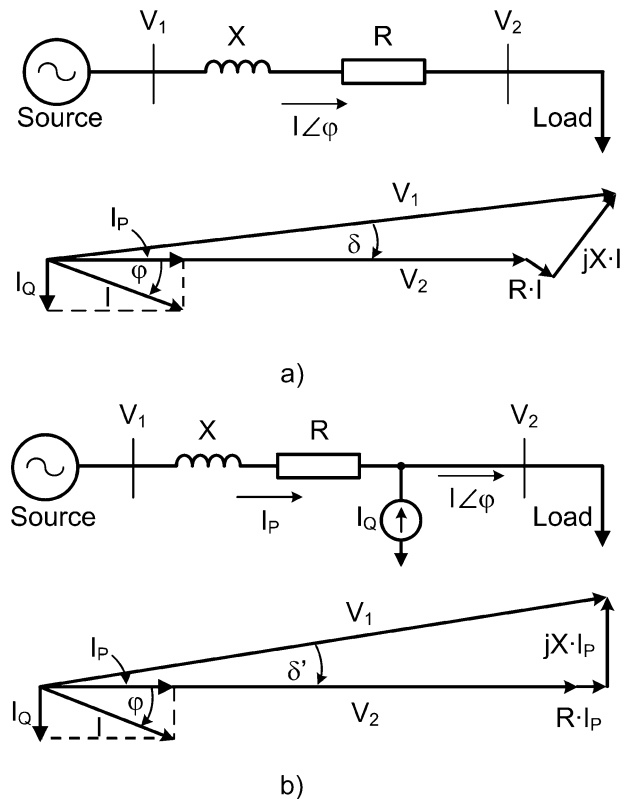

Fig. 1. Principles of shunt compensation in a radial ac system. (a) Without reactive compensation. (b) Shunt compensation with a current source.

the reactive current component from the source is reduced or almost eliminated.

If the load needs leading compensation, then an inductor would be required. Also, a current source or a voltage source can be used for inductive shunt compensation. The main advantage of using voltage- or current-source Var generators (instead of inductors or capacitors) is that the reactive power generated is independent of the voltage at the point of connection.

B. Series Compensation

Var compensation can also be of the series type. Typical series compensation systems use capacitors to decrease the equivalent reactance of a power line at rated frequency. The connection of a series capacitor generates reactive power that, in a self-regulated manner, balances a fraction of the line's transfer reactance. The result is improved functionality of the power transmission system through:

- 1) increased angular stability of the power corridor;
- 2) improved voltage stability of the corridor;
- 3) optimized power sharing between parallel circuits.

Like shunt compensation, series compensation may also be implemented with current- or voltage-source devices, as shown in Fig. 2. Fig. 2(a) shows the same power system of Fig. 1(a), also with the reference angle in V_2 , and Fig. 2(b) shows the results obtained with the series compensation through a voltage source, which has been adjusted again to have unity power factor operation at V_2 . However, the compensation strategy is different when compared with

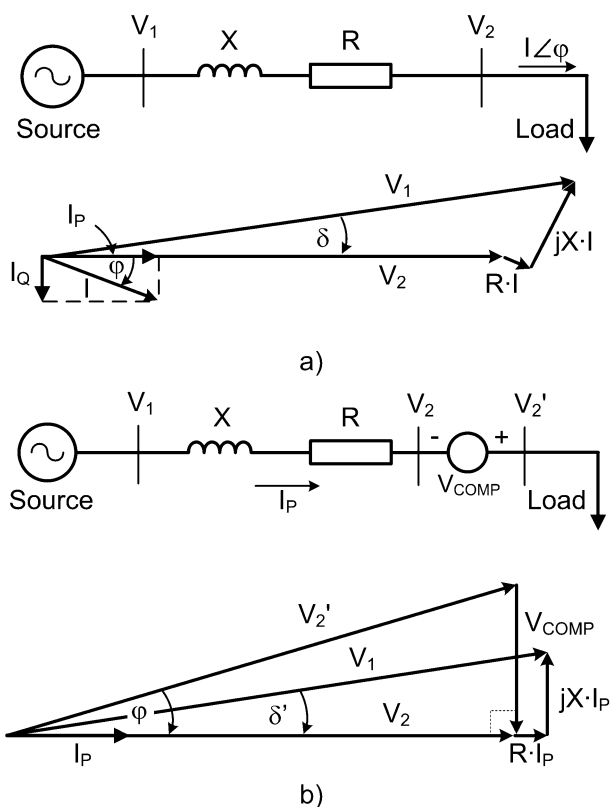

Fig. 2. Principles of series compensation. a) The same system of Fig. 1(a) without compensation. b) Series compensation with a voltage source.

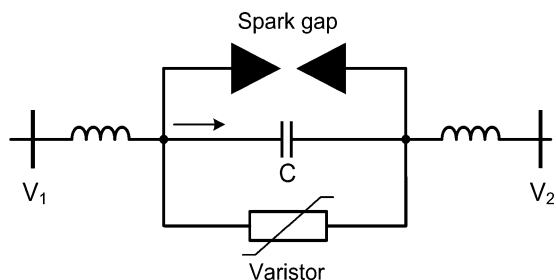

Fig. 3. Series capacitor compensator and associated protection system.

shunt compensation. In this case, voltage V_{COMP} has been added between the line and the load to change the angle of V_2' , which is now the voltage at the load side. With the appropriate magnitude adjustment of V_{COMP} , unity power factor can again be reached at V_2 . As can be seen from the phasor diagram of Fig. 2(b), V_{COMP} generates a voltage with opposite direction to the voltage drop in the line inductance because it lags the current I_P .

As was already mentioned, series compensation with capacitors is the most common strategy. Series capacitors are installed in series with a transmission line as shown in Fig. 3, which means that all the equipment must be installed on a platform that is fully insulated for the system voltage (both the terminals are at the line voltage). On this platform, the main capacitor is located together with overvoltage protection circuits. The overvoltage protection is a key design factor as the capacitor bank has to withstand the

throughput fault current, even at a severe nearby fault. The primary overvoltage protection typically involves nonlinear metal-oxide varistors, a spark gap, and a fast bypass switch. Secondary protection is achieved with ground mounted electronics acting on signals from optical current transducers in the high-voltage circuit.

Independent of the source type or system configuration, different requirements have to be taken into consideration for a successful operation of Var generators. Some of these requirements are simplicity, controllability, dynamics, cost, reliability, and harmonic distortion. The following sections describe different solutions used for Var generation with their associated principles of operation and compensation characteristics.

III. TRADITIONAL VAR GENERATORS

In general, Var generators are classified depending on the technology used in their implementation and the way they are connected to the power system (shunt or series). Rotating and static generators were commonly used to compensate reactive power. In the last decade, a large number of different static Var generators using power electronic technologies have been proposed and developed [7]. There are two approaches to the realization of power electronics based Var compensators: the one that employs thyristor-switched capacitors and reactors with tap-changing transformers, and the other that uses self-commutated static converters. A brief description of the most commonly used shunt and series compensators is presented below.

A. Fixed or Mechanically Switched Capacitors

Shunt capacitors were first employed for power factor correction in 1914 [16]. The leading current drawn by the shunt capacitors compensates the lagging current drawn by the load. The selection of shunt capacitors depends on many factors, the most important of which is the amount of lagging reactive power taken by the load. In the case of widely fluctuating loads, the reactive power also varies over a wide range. Thus, a fixed capacitor bank may often lead to either over-compensation or under-compensation. Variable Var compensation is achieved using switched capacitors [17]. Depending on the total Var requirement, capacitor banks are switched into or switched out of the system. The smoothness of control is solely dependent on the number of capacitors switching units used. The switching is usually accomplished using relays and circuit breakers. However, these methods based on mechanical switches and relays have the disadvantage of being sluggish and unreliable. Also they generate high inrush currents, and require frequent maintenance [16].

B. Synchronous Condensers

Synchronous condensers have played a major role in voltage and reactive power control for more than 50 years. Functionally, a synchronous condenser is simply a synchronous machine connected to the power system. After the unit is synchronized, the field current is adjusted to either

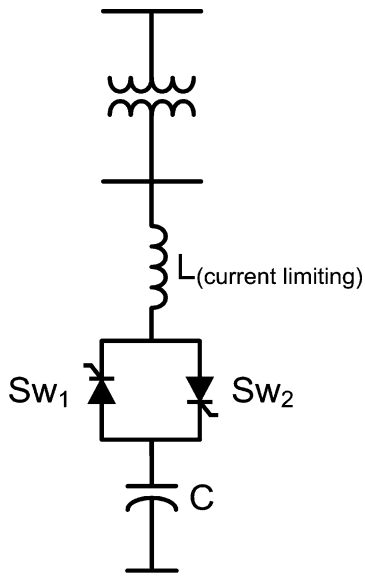

Fig. 4. TSC configuration.

generate or absorb reactive power as required by the ac system. The machine can provide continuous reactive power control when used with the proper automatic exciter circuit. Synchronous condensers have been used at both distribution and transmission voltage levels to improve stability and to maintain voltages within desired limits under varying load conditions and contingency situations. However, synchronous condensers are rarely used today because they require substantial foundations and a significant amount of starting and protective equipment. They also contribute to the short-circuit current, and they cannot be controlled fast enough to compensate for rapid load changes. Moreover, their losses are much higher than those associated with static compensators, and the cost is much higher compared with static compensators. Their advantage lies in their high temporary overload capability [1].

C. Thyristorized Var Compensators

As in the case of the synchronous condenser, the aim of achieving fine control over the entire Var range, has been fulfilled with the development of static compensators but with the advantage of faster response times [6], [7]. SVCs consist of standard reactive power shunt elements (reactors and capacitors) which are controlled to provide rapid and variable reactive power. They can be grouped into two basic categories, the TSC and the TCR.

1) *TSCs*: Fig. 4 shows the basic scheme of a static compensator of the TSC type. First introduced by ASEA in 1971 [16], the shunt capacitor bank is split up into appropriately small steps, which are individually switched in and out using bidirectional thyristor switches. Each single-phase branch consists of two major parts, the capacitor C and the thyristor switches Sw_1 and Sw_2 . In addition, there is a minor component, the inductor L , whose purpose is to limit the rate of rise of the current through the thyristors and to prevent resonance with the network (normally 6% with respect to X_c). The capacitor may be switched with a minimum of transients

if the thyristor is turned on at the instant when the capacitor voltage and the network voltage have the same value. Static compensators of the TSC type have the following properties: stepwise control, average delay of one half a cycle (maximum one cycle), and no generation of harmonics, since current transient component can be attenuated effectively [16], [17].

The current that flows through the capacitor at a given time t is defined by the following expression:

$$i(t) = \frac{V_m}{X_C - X_L} \cos(\omega t + \alpha) - \frac{V_m}{X_C - X_L} \cos(\alpha) \cos(\omega_r t) + \left[\frac{X_C V_m \sin(\alpha)}{\omega_r L (X_C - X_L)} - \frac{V_{CO}}{\omega_r L} \right] \sin(\omega_r t) \quad (1)$$

where X_c and X_L are the compensator capacitive and inductive reactance, V_m the source maximum instantaneous voltage, α the voltage phase-shift angle at which the capacitor is connected, and ω_r the system resonant frequency ($\omega_r = 1/\sqrt{LC}$), V_{CO} capacitor voltage at $t = 0^-$.

This expression has been obtained assuming that the system equivalent resistance is negligible as compared with the system reactance. This assumption is valid in high-voltage transmission lines. If the capacitor is connected at the moment that the source voltage is maximum and V_{CO} is equal to the source voltage peak value V_m ($\alpha = \pm 90^\circ$) the current transient component is zero.

Despite the attractive theoretical simplicity of the switched capacitor scheme, its popularity has been hindered by a number of practical disadvantages: the Var compensation is not continuous, each capacitor bank requires a separate thyristor switch and therefore the construction is not economical, the steady state voltage across the nonconducting thyristor switch is twice the peak supply voltage, and the thyristor must be rated for or protected by external means against line voltage transients and fault currents.

An attractive solution to the disadvantages of using TSCs is to replace one of the thyristor switches by a diode. In this case, inrush currents are eliminated when thyristors are fired at the right time, and a more continuous reactive power control can be achieved if the rated power of each capacitor bank is selected following a binary combination, as described in [13] and [18]. This configuration is shown in Fig. 5. In this figure, the inductor L_{min} is used to prevent any inrush current produced by a firing pulse out of time.

To connect each branch, a firing pulse is applied at the thyristor gate, but only when the voltage supply reaches its maximum negative value. In this way, a soft connection is obtained (1). The current will increase starting from zero without distortion, following a sinusoidal waveform, and after the cycle is completed, the capacitor voltage will have the voltage $-V_m$, and the thyristor automatically will block. In this form of operation, both connection and disconnection of the branch will be soft, and without distortion. If the firing pulses and the voltage $-V_m$ are properly adjusted, neither harmonics nor inrush currents are generated, since two important conditions are achieved: 1) dv/dt at $v = -V_m$

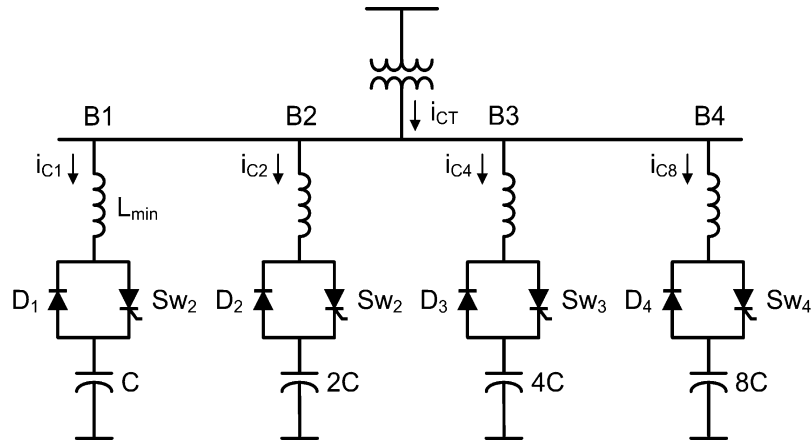

Fig. 5. Binary thyristor-diode-switched capacitor configuration.

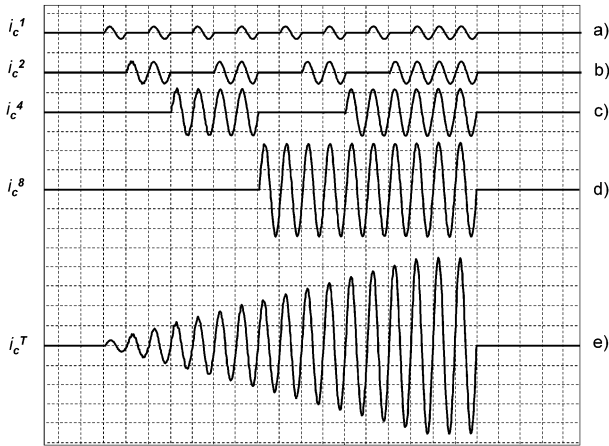

Fig. 6. Experimental compensating phase current of the thyristor-diode switched capacitor. (a) Current through B1. (b) Current through B2. (c) Current through B3. (d) Current through B4. (e) Total system compensating current.

is zero and 2) anode-to-cathode thyristor voltage is equal to zero. Assuming that $v(t) = V_m \sin \omega t$, is the source voltage, V_{co} the initial capacitor voltage, and $v^{Th}(t)$ the thyristor anode-to-cathode voltage, the right connection of the branch will be when $v^{Th}(t) = 0$, that is

$$v^{Th}(t) = v(t) - V_{co} = V_m \sin \omega t - V_{co} \quad (2)$$

since $V_{co} = -V_m$

$$v^{Th}(t) = V_m \sin \omega t + V_m = V_m(1 + \sin \omega t) \quad (3)$$

then $v^{Th}(t) = 0$ when $\sin \omega t = -1 \Rightarrow \omega t = 270^\circ$.

At $\omega t = 270^\circ$, the thyristor is switched on, and the capacitor C begins to discharge. At this point, $\sin(270^\circ) = -\cos(0^\circ)$, and hence $v_c(t)$ for $\omega t \geq 270^\circ$ will be $v_c(t_o) = -V_m \cos \omega t_o$. The compensating capacitor current starting at t_o will be

$$i_c = C \frac{dv_c}{dt} = C \cdot V_m \frac{d}{dt}(-\cos \omega \cdot t_o) = C \cdot V_m \sin \omega \cdot t_o. \quad (4)$$

Equation (4) shows that the current starts from zero as a sinusoidal waveform without distortion and/or inrush component. If the above switching conditions are satisfied, the inductor L may be minimized or even eliminated.

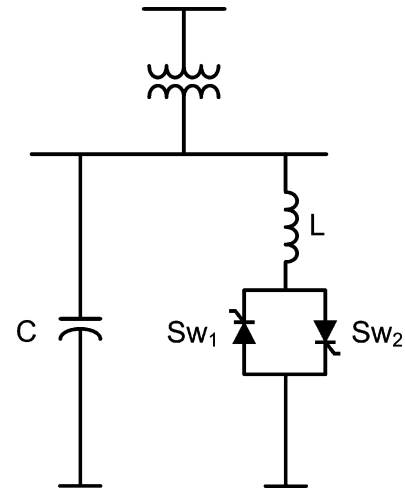

Fig. 7. TCR configuration.

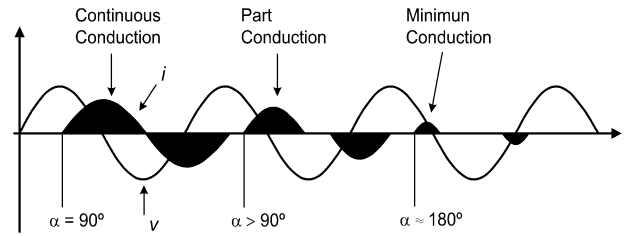

Fig. 8. Simulated voltage and current waveforms in a TCR for different thyristor phase-shift angles, α .

The experimental oscillograms of Fig. 6 shows how the binary connection of many branches allows an almost continuous compensating current variation. These experimental current waveforms were obtained in a 5-kVAR laboratory prototype. The advantages of this topology are that many compensation levels can be implemented with few branches allowing continuous variations without distortion. Moreover, the topology is simpler and more economical as compared with TSCs. The main drawback is that it has a time delay of one complete cycle compared with the half cycle of TSCs.

2) TCR: Fig. 7 shows the scheme of a static compensator of the TCR type. In most cases, the compensator also includes a fixed capacitor and a filter for low order harmonics,

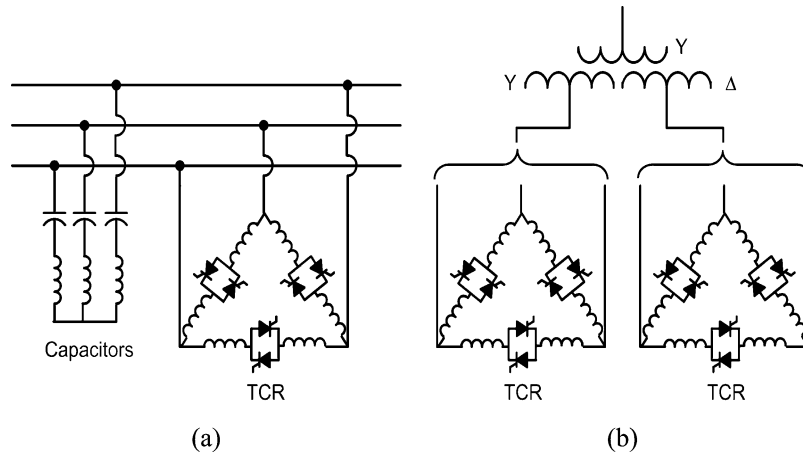

Fig. 9. FC-TCR configuration. (a) Six-pulse topology. (b) Twelve-pulse topology.

which is not shown in this figure. Each of the three phase branches includes an inductor L , and the thyristor switches Sw_1 and Sw_2 . Reactors may be both switched and phase-angle controlled [20]–[22].

When phase-angle control is used, a continuous range of reactive power consumption is obtained. It results, however, in the generation of odd harmonic current components during the control process. Full conduction is achieved with a gating angle of 90° . Partial conduction is obtained with gating angles between 90° and 180° , as shown in Fig. 8. By increasing the thyristor gating angle, the fundamental component of the current reactor is reduced. This is equivalent to increase the inductance, reducing the reactive power absorbed by the reactor. However, it should be pointed out that the change in the reactor current may only take place at discrete points of time, which means that adjustments cannot be made more frequently than once per half-cycle. Static compensators of the TCR type are characterized by the ability to perform continuous control, maximum delay of one half-cycle, and practically no transients. The principal disadvantages of this configuration are the generation of low-frequency harmonic current components, and higher losses when working in the inductive region (i.e., absorbing reactive power) [20].

The relation between the fundamental component of the reactor current, and the phase-shift angle α is given by (5)

$$I_1 = \frac{V_{rms}}{\pi\omega L} (2\pi - 2\alpha + \sin(2\alpha)). \quad (5)$$

In a single-phase unit, with balanced phase-shift angles, only odd harmonic components are presented in the current of the reactor. The amplitude of each harmonic component is defined by (6)

$$I_k = \frac{4V_{rms}}{\pi X_L} \left[\frac{\sin(k+1)\alpha}{2(k+1)} + \frac{\sin(k-1)\alpha}{2(k-1)} - \cos(\alpha) \frac{\sin(k\alpha)}{k} \right]. \quad (6)$$

In order to eliminate low-frequency current harmonics (third, fifth, seventh), delta configurations (for zero sequence

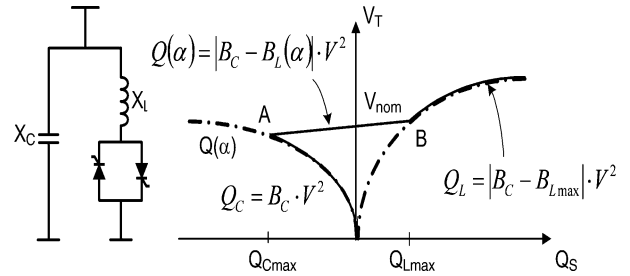

Fig. 10. Voltage-reactive power characteristic of a FC-TCR.

harmonics) and passive filters may be used, as shown in Fig. 9(a). Twelve pulse configurations are also used as shown in Fig. 9(b). In this case passive filters are not required, since the fifth and seventh current harmonics are eliminated by the phase-shift introduced by the transformer.

3) *Var Compensation Characteristics*: One of the main characteristics of SVCs is that the amount of reactive power interchanged with the system depends on the applied voltage, as shown in Fig. 10. This figure displays the steady state Q - V characteristics of a combination of fixed capacitor-TCR (FC-TCR) compensator. This characteristic shows the amount of reactive power generated or absorbed by the FC-TCR, as a function of the applied voltage. At rated voltage, the FC-TCR presents a linear characteristic, which is limited by the rated power of the capacitor and reactor respectively. Beyond these limits, the $V_T - Q$ characteristic is not linear [1], [7], which is one of the principal disadvantages of this type of Var compensator.

4) *Combined TSC and TCR*: Irrespective of the reactive power control range required, any static compensator can be built up from one or both of the above mentioned schemes (i.e., TSC and TCR), as shown in Fig. 11. In those cases where the system with switched capacitors is used, the reactive power is divided into a suitable number of steps and the variation will therefore take place stepwise. Continuous control may be obtained with the addition of a TCR. If it is required to absorb reactive power, the entire capacitor bank is disconnected and the equalizing reactor becomes responsible for the absorption. By coordinating the control between

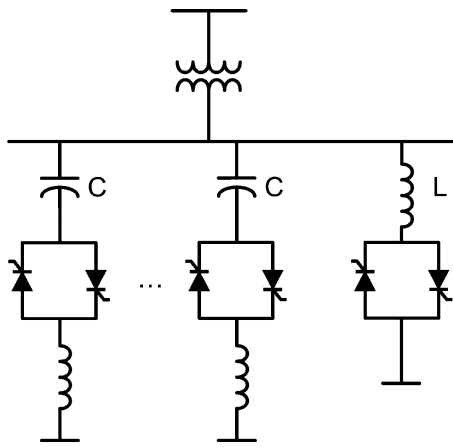

Fig. 11. Combined TSC and TCR configuration.

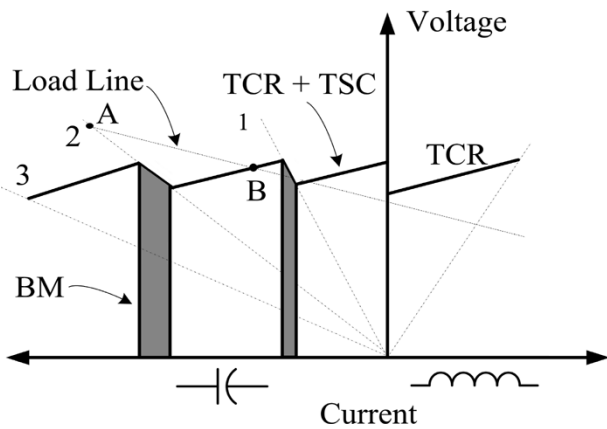

Fig. 12. Steady-state voltage-reactive power characteristic of a combined TSC-TCR compensator.

the reactor and the capacitor steps, it is possible to obtain fully stepless control. Static compensators of the combined TSC and TCR type are characterized by a continuous control, practically no transients, low generation of harmonics (because the controlled reactor rating is small compared to the total reactive power), and flexibility in control and operation. An obvious disadvantage of the TSC-TCR as compared with TCR and TSC type compensators is the higher cost. A smaller TCR rating results in some savings, but these savings are more than absorbed by the cost of the capacitor switches and the more complex control system [16].

The V-Q characteristic of this compensator is shown in Fig. 12.

To reduce transient phenomena and harmonics distortion, and to improve the dynamics of the compensator, some researchers have applied self-commutation to TSC and TCR. Some examples of this can be found in [21] and [22]. However, best results have been obtained using self-commutated compensators based on conventional two-level and three-level inverters. They are analyzed in Section IV.

5) *Thyristor-Controlled Series Compensation:* Fig. 13 shows a single line diagram of a thyristor-controlled series compensator (TCSC). The TCSC provides a proven technology that addresses specific dynamic problems in transmission systems. TCSCs are an excellent tool to

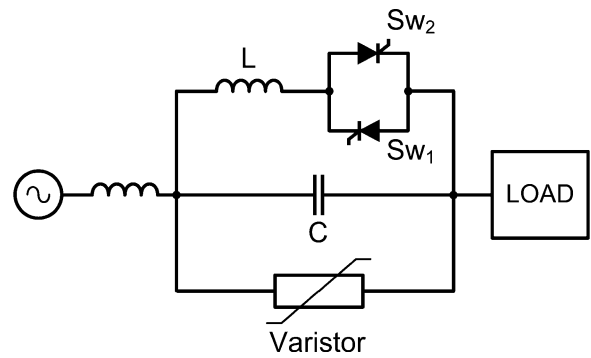

Fig. 13. Power circuit topology of a TCSC.

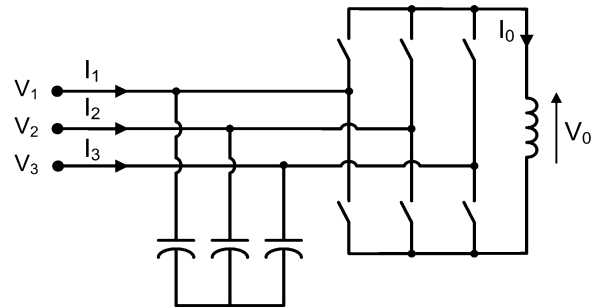

Fig. 14. A Var compensator topology implemented with a current-source converter.

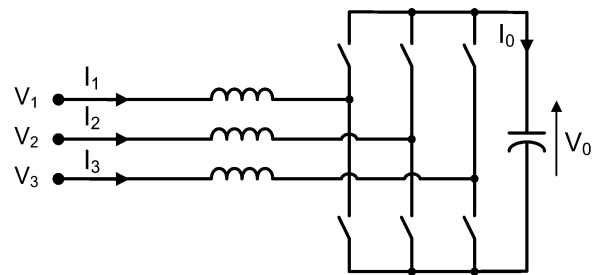

Fig. 15. A Var compensator topology implemented with a VSC.

introduce if increased damping is required when interconnecting large electrical systems. Additionally, they can overcome the problem of subsynchronous resonance (SSR), a phenomenon that involves an interaction between large thermal generating units and series compensated transmission systems.

There are two bearing principles of the TCSC concept. First, the TCSC provides electromechanical damping between large electrical systems by changing the reactance of a specific interconnecting power line, i.e., the TCSC will provide a variable capacitive reactance. Second, the TCSC shall change its apparent impedance (as seen by the line current) for subsynchronous frequencies such that a prospective SSR is avoided. Both these objectives are achieved with the TCSC using control algorithms that operate concurrently. The controls will function on the thyristor circuit (in parallel to the main capacitor bank) such that controlled charges are added to the main capacitor, making it a variable capacitor at fundamental frequency but a “virtual inductor” at subsynchronous frequencies.

For power oscillation damping, the TCSC scheme introduces a component of modulation of the effective reactance

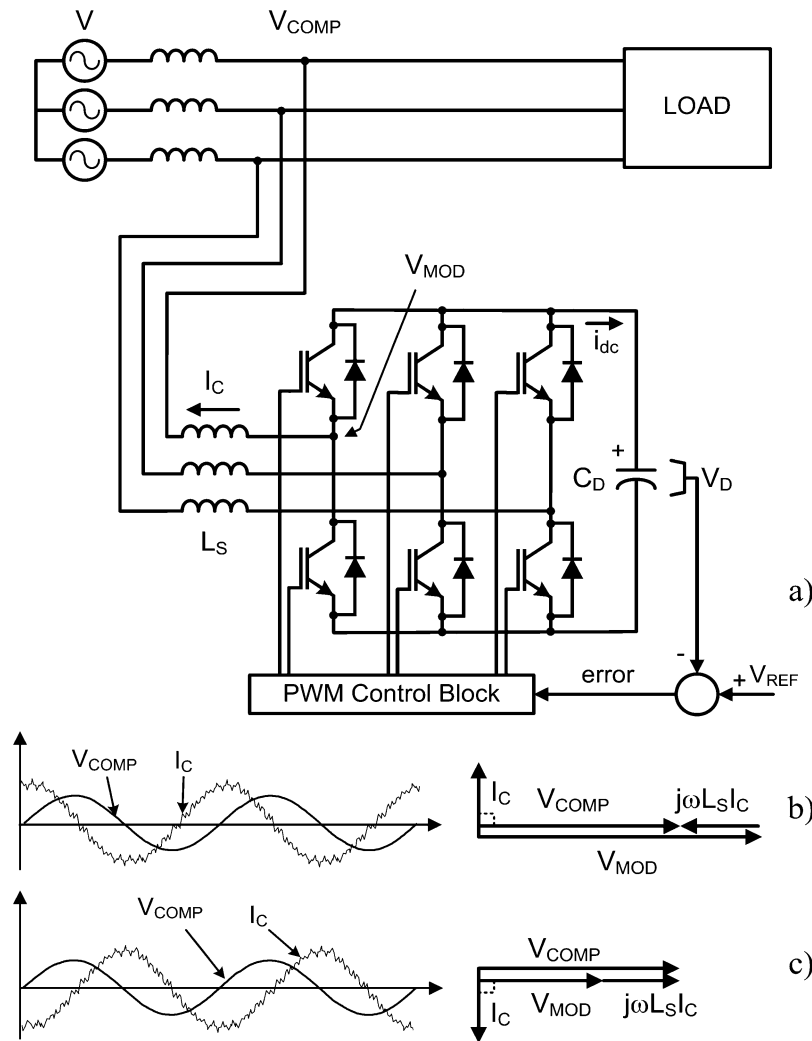

Fig. 16. Simulated current and voltage waveforms of a voltage-source self-commutated shunt Var compensator. (a) Compensator topology. (b) Simulated current and voltage waveforms for leading compensation ($V_{MOD} > V_{COMP}$). (c) Simulated current and voltage waveforms for lagging compensation ($V_{MOD} < V_{COMP}$).

of the power transmission corridor. By suitable system control, this modulation of the reactance is made to counteract the oscillations of the active power transfer, in order to damp these out.

IV. SELF-COMMUTATED VAR COMPENSATORS

The application of self-commutated (also known as force-commutated) converters as a means of compensating reactive power has demonstrated to be an effective solution. This technology has been used to implement more sophisticated compensator equipment such as static synchronous compensators (STATCOMs), UPFCs, and DVRs [15], [19].

A. Principles of Operation

With the remarkable progress of gate commutated semiconductor devices, attention has been focused on self-commutated Var compensators capable of generating or absorbing reactive power without requiring large banks of capacitors or reactors. Several approaches are possible including current-source and voltage-source converters (VSCs). The current-source approach shown in Fig. 14 uses a reactor supplied with a regulated dc current, while the

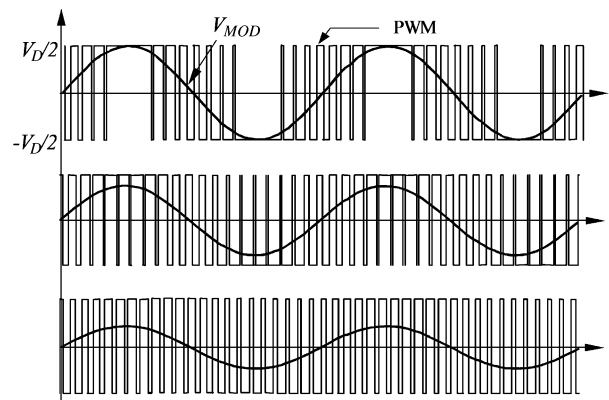

Fig. 17. Simulated compensator output voltage waveform for different modulation index (amplitude of the voltage fundamental component).

voltage-source inverter, displayed in Fig. 15, uses a capacitor with a regulated dc voltage.

The principal advantages of self-commutated Var compensators are the significant reduction of size and the potential reduction in cost achieved from the elimination of a large number of passive components and lower relative

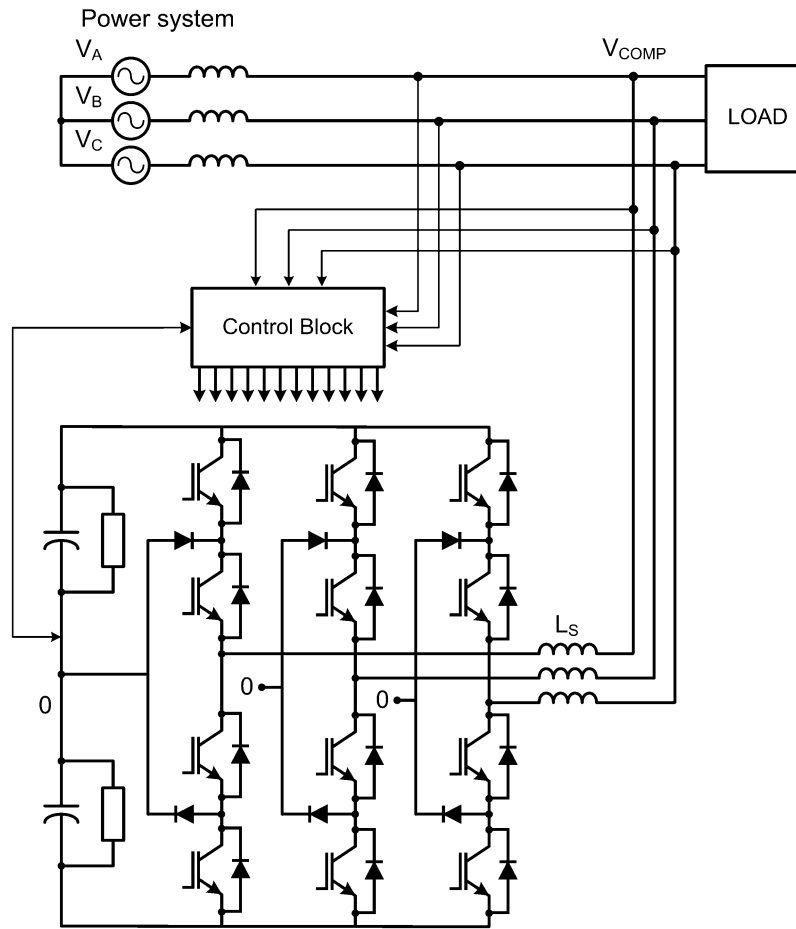

Fig. 18. A shunt Var compensator implemented with a three-level NPC inverter.

capacity requirement for the semiconductor switches [19], [23]. Because of their smaller size, self-commutated Var compensators are well suited for applications where space is a premium.

Self-commutated compensators are used to stabilize transmission systems, improve voltage regulation, correct power factor, and also correct load imbalances [19], [23]. Moreover, they can be used for the implementation of shunt and series compensators. Fig. 16 shows a shunt Var compensator, implemented with a boost-type VSC. Neglecting the internal power losses of the overall converter, the control of the reactive power is done by adjusting the amplitude of the fundamental component of the output voltage V_{MOD} , which can be modified with the PWM pattern as shown in Fig. 17. When V_{MOD} is larger than the voltage V_{COMP} , the Var compensator generates reactive power [Fig. 16(b)] and when V_{MOD} is smaller than V_{COMP} , the compensator absorbs reactive power [Fig. 16(c)]. Its principle of operation is similar to the synchronous machine. The compensation current can be leading or lagging, depending of the relative amplitudes of V_{COMP} and V_{MOD} . The capacitor voltage V_D , connected to the dc link of the converter, is kept constant and equal to a reference value V_{REF} with a special feedback control loop, which controls the phase-shift angle between V_{COMP} and V_{MOD} .

The amplitude of the compensator output voltage (V_{MOD}) can be controlled by changing the switching pattern modu-

lation index (Fig. 17) or by changing the amplitude of the converter dc voltage V_D . Faster time response is achieved by changing the switching pattern modulation index instead of V_D . The converter dc voltage V_D is changed by adjusting the small amount of active power absorbed by the converter and defined by (7)

$$P = \frac{V_{COMP} \cdot V_{MOD}}{X_S} \sin(\delta) \quad (7)$$

where X_s is the converter linked reactor, and δ is the phase-shift angle between voltages V_{COMP} and V_{MOD} .

One of the major problems that must be solved to use self-commutated converters in high-voltage systems is the limited capacity of the controlled semiconductors [insulated gate bipolar transistors (IGBTs) and integrated gate commutated thyristors (IGCTs)] available in the market. Actual semiconductors can handle a few thousands of amperes and 6–10-kV reverse voltage blocking capabilities, which is clearly not enough for high-voltage applications. This problem can be overcome by using more sophisticated converters topologies, as described below.

B. Multilevel Compensators

Multilevel converters are being investigated and some topologies are used today as SVCs. The main advantages of multilevel converters are less harmonic generation and

higher voltage capability because of serial connection of bridges or semiconductors. The most popular arrangement today is the three-level neutral-point clamped (NPC) topology.

1) *Three-Level Compensators*: Fig. 18 shows a shunt Var compensator implemented with a three-level NPC converter.

Three-level converters [24] are becoming the standard topology for medium voltage converter applications, such as machine drives and active front-end rectifiers. The advantage of three-level converters is that they can reduce the generated harmonic content, since they produce a voltage waveform with more levels than the conventional two-level topology. Another advantage is that they can reduce the semiconductor's voltage rating and the associated switching frequency. Three-level converters consist of 12 self-commutated semiconductors such as IGBTs or IGCTs, each of them shunted by a reverse parallel connected power diode, and six diode branches connected between the midpoint of the dc link bus and the midpoint of each pair of switches as shown in Fig. 18. By connecting the dc source sequentially to the output terminals, the converter can produce a set of PWM signals in which the frequency, amplitude, and phase of the ac voltage can be modified with adequate control signals.

2) *Multilevel Converters With Carriers Shifted*: Another exciting technology that has been successfully proven uses basic "H" bridges as shown in Fig. 19, connected to line through power transformers. These transformers are connected in parallel at the converter side, and in series at the line side [25]. The system uses sinusoidal pulsewidth modulation (SPWM) with triangular carriers shifted and depending on the number of converters connected in the chain of bridges, the voltage waveform becomes more and more sinusoidal. Fig. 19(a) shows one phase of this topology implemented with eight "H" bridges, and Fig. 19(b) shows the voltage waveforms obtained as a function of number of "H" bridges.

An interesting result with this converter is that the ac voltages become modulated by pulsewidth and by amplitude (PWM and AM). This is because when the pulse modulation changes, the steps of the amplitude also changes. The maximum number of steps of the resultant voltage is equal to two times the number of converters plus the zero level. Then four bridges will result in a nine-level converter per phase.

Fig. 20 shows the AM operation. When the voltage decreases, some steps disappear, and then the amplitude modulation becomes a discrete function.

3) *Optimized Multilevel Converter*: The number of levels can increase rapidly with few converters when voltage scalation is applied. In a similar way of converter in Fig. 19(a), the topology of Fig. 21(a) has a common dc link with voltage isolation through output transformers, connected in series at the line side. However, the voltages at the line side are scaled in power of three. By using this strategy, the number of voltage steps is maximized and few converters are required to obtain almost sinusoidal voltage waveforms. In the example of Fig. 21, amplitude modulation with 81 levels of voltage is obtained using only four "H" converters per phase (four-stage inverter). In this way, Var compensators with "harmonic-free" characteristics can be implemented.

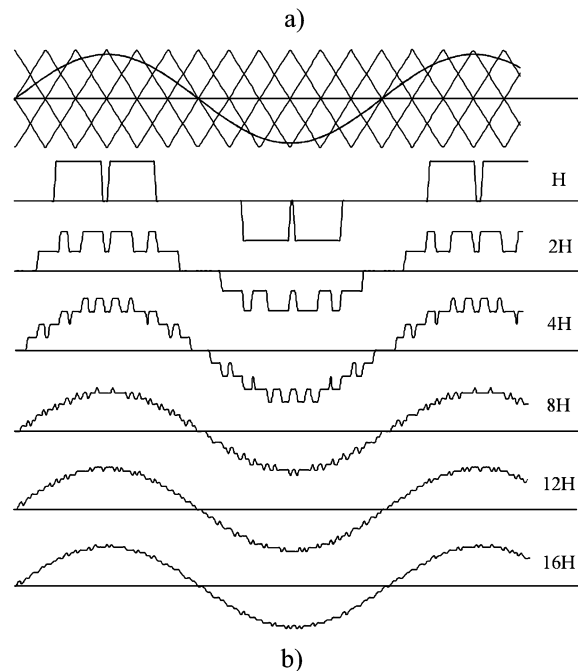
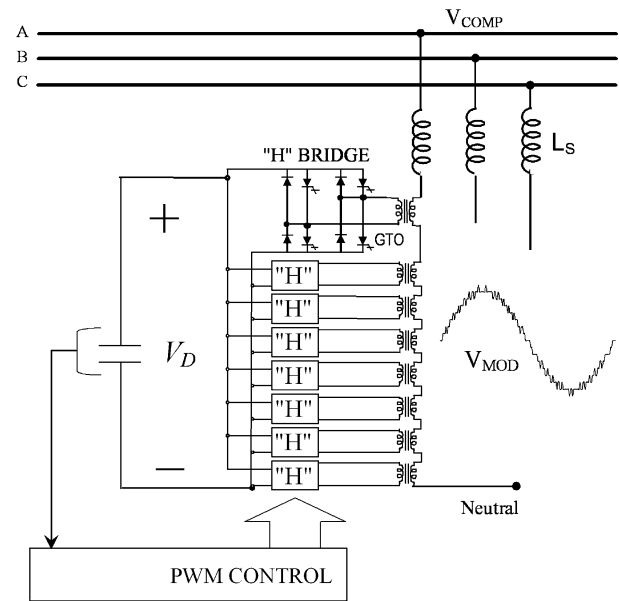

Fig. 19. (a) Multilevel converter with eight "H" bridges and triangular carriers shifted (b) Voltage quality as a function of number of bridges.

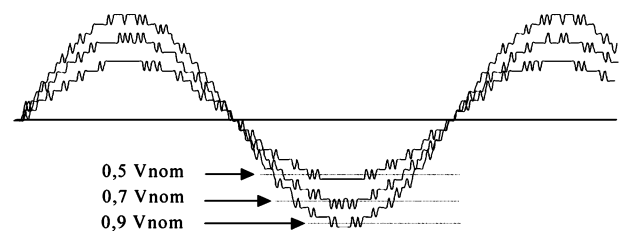

Fig. 20. Amplitude modulation in topology of Fig. 19(a).

It is important to remark that the bridge with the higher voltage is being commutated at the line frequency, which is a major advantage of this topology for high-power applications. Another interesting characteristic of this converter,

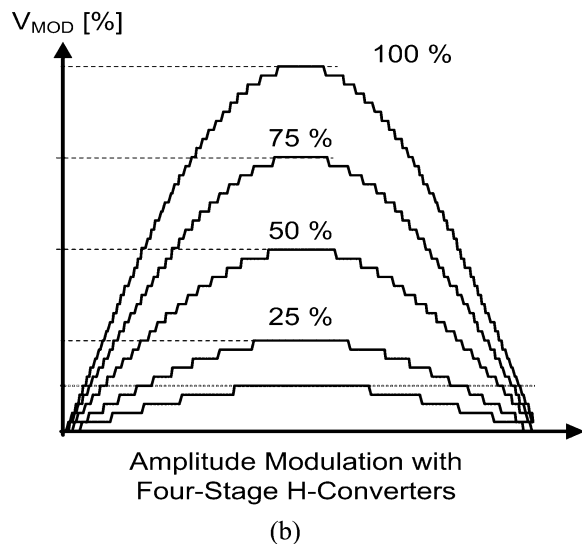
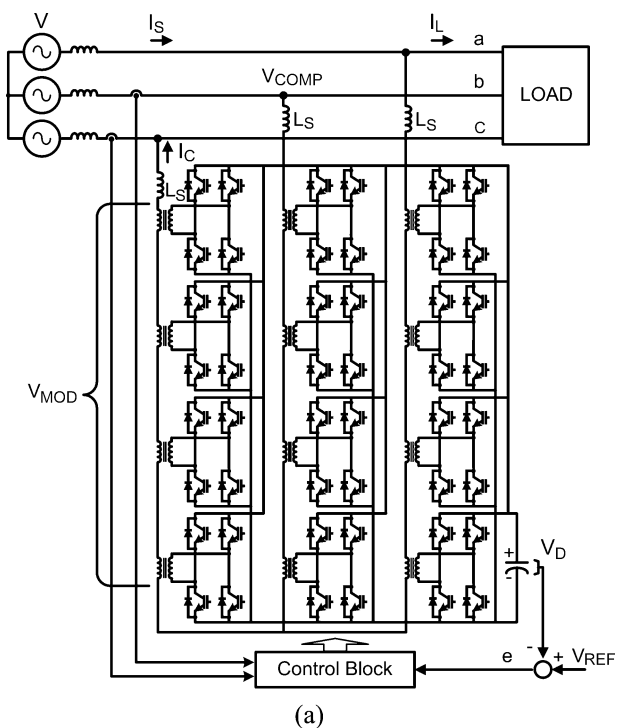

Fig. 21. (a) Four-stage, 81-level Var compensator, using “H” bridges scaled in power of three. (b) Converter output using amplitude modulation.

compared with the multilevel strategy with carriers shifted, is that only four “H” bridges per phase are required to get 81 levels of voltage. In the previous multilevel converter with carriers shifted, 40 “H” bridges instead of four are required.

For high-power applications, probably a less complicated three-stage (three “H” bridges per phase) is enough. In this case, 27 levels or steps of voltage are obtained, which will provide good enough voltage and current waveforms for high-quality operation [26].

C. Semiconductor Devices Used for Self-Commutated Var Compensators

Three are the most relevant devices for applications in SVC: thyristors, IGBTs, and IGCTs. This field of applica-

tion requires that the semiconductor must be able to block high voltages in the kV range. High-voltage IGBTs required to apply self-commutated converters in SVC reach now the level of 6.5 kV, allowing for the construction of circuits with a power of several MW. Also IGCTs are reaching now the level of 6 kV. Perhaps the most important development in semiconductors for SVC applications is the light-triggered thyristor (LTT). This device is the most important for ultra-high-power applications. Recently, LTT devices have been developed with a capability of up to 13.5 kV and a current of up to 6 kA. These new devices reduce the number of elements in series and in parallel, reducing consequently the number of gate and protection circuits. With these elements, it is possible to reduce cost and increase reactive power in SVC installations of up to several hundreds of MVARs [27].

D. Comparison Between Thyristorized and Self-Commutated Compensators

As compared with thyristor-controlled capacitor and reactor banks, self-commutated Var compensators have the following advantages.

- 1) They can provide both leading and lagging reactive power, thus enabling a considerable saving in capacitors and reactors. This in turn reduces the possibility of resonances at some critical operating conditions.
- 2) Since the time response of self-commutated converter can be faster than the fundamental power network cycle, reactive power can be controlled continuously and precisely.
- 3) High frequency modulation of self-commutated converter results in a low harmonic content of the supply current, thus reducing the size of filter components.
- 4) They do not generate inrush current.
- 5) The dynamic performance under voltage variations and transients is improved.
- 6) Self-commutated Var compensators are capable of generating 1 p.u. reactive current even when the line voltages are very low. This ability to support the power system is better than that obtained with thyristor-controlled Var compensators because the current in shunt capacitors and reactors is proportional to the voltage.
- 7) Self-commutated compensators with appropriate control can also act as active line harmonic filters, DVRs, or UPFCs.

Table 1 summarizes the comparative merits of the main types of Var compensators. The significant advantages of self-commutated compensators make them an interesting alternative to improve compensation characteristics and also to increase the performance of ac power systems.

Fig. 22 shows the voltage/current characteristic of a self-commutated Var compensator compared with that of thyristor-controlled SVC. This figure illustrates that the self-commutated compensator offers better voltage support and improved transient stability margin by providing more reactive power at lower voltages. Because no large capacitors and reactors are used to generate reactive power, the self-commutated compensator provides faster time response and better stability to variations in system impedances.

Table 1
Comparison of Basic Types of Compensators

	Synchronous Condenser	Static Compensator		Self-commutated Compensator
		TCR (with shunt capacitors if necessary)	TSC (with TCR if necessary)	
Accuracy of Compensation	Good	Very Good	Good, very good with TCR	Excellent
Control Flexibility	Good	Very Good	Good, very good with TCR	Excellent
Reactive Power Capability	Leading/Lagging	Lagging/Leading indirect	Leading/Lagging indirect	Leading/Lagging
Control	Continuous	Continuous	Discontinuous (cont. with TCR)	Continuous
Response Time	Slow	Fast, 0.5 to 2 cycles	Fast, 0.5 to 2 cycles	Very fast but depends on the control system and switching frequency
Harmonics	Very Good	Very high (large-size filters are needed)	Good, filters are necessary with TCR	Good, but depends on switching pattern
Losses	Moderate	Good, but increase in lagging mode	Good, but increase in leading mode	Very good, but increase with switching frequency
Phase Balancing Ability	Limited	Good	Limited	Very good with 1- ϕ units, limited with 3- ϕ units
Cost	High	Moderate	Moderate	Low to moderate

V. NEW VAR COMPENSATOR'S TECHNOLOGY

Based on power electronics converters and digital control schemes, reactive power compensators implemented with self-commutated converters have been developed to compensate not only reactive power, but also voltage regulation, flicker, harmonics, real and reactive power, transmission line impedance, and phase-shift angle. It is important to note, that even though the final effect is to improve power system performance, the control variable in all cases is basically the reactive power. Using self-commutated converters, the following high-performance power system controllers have been implemented: the STATCOM, the static synchronous series compensator (SSSC), the DVR, the UPFC, the inter-line power flow controller (IPFC), and the superconducting magnetic energy storage (SMES). The principles of operation and power circuit topology of each one are described below.

A. STATCOM

The STATCOM is based on a solid-state voltage source, implemented with an inverter and connected in parallel to the power system through a coupling reactor, in analogy with a synchronous machine, generating balanced set of three sinusoidal voltages at the fundamental frequency, with controllable amplitude and phase-shift angle. This equipment, however, has no inertia and no overload capability. Examples of these topologies are Figs. 16, 18 and 19 [19], [28].

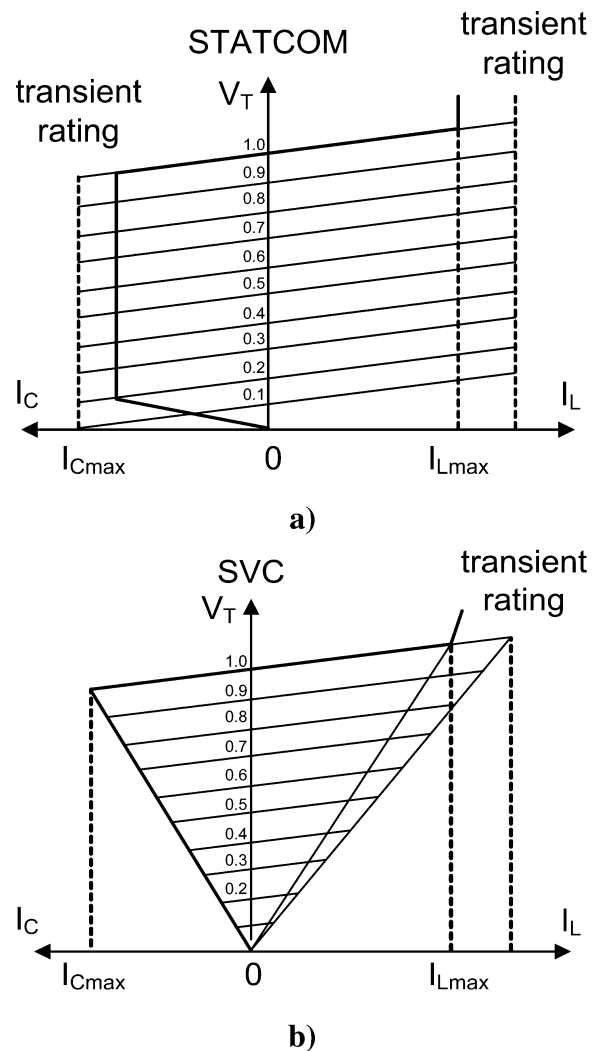

Fig. 22. Voltage-current characteristics of shunt Var compensators. (a) Compensator implemented with self-commutated converter (STATCOM). (b) Compensator implemented with back-to-back thyristors.

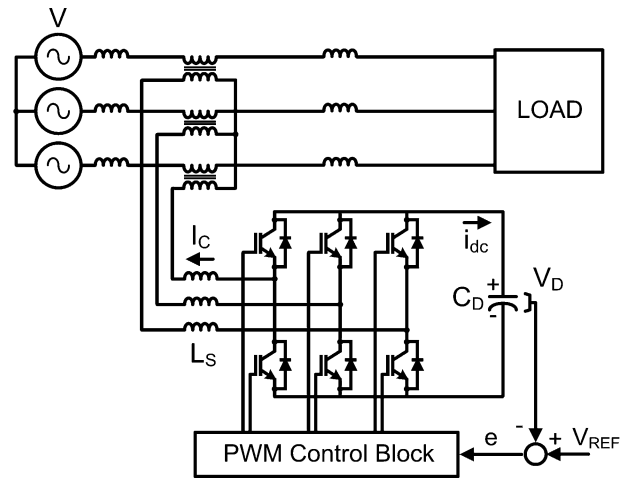

Fig. 23. SSSC.

B. SSSC

A VSC can also be used as a series compensator as shown in Fig. 23. The SSSC injects a voltage in series to the line, 90° phase-shifted with the load current, operating as a controllable series capacitor. The basic difference, as compared

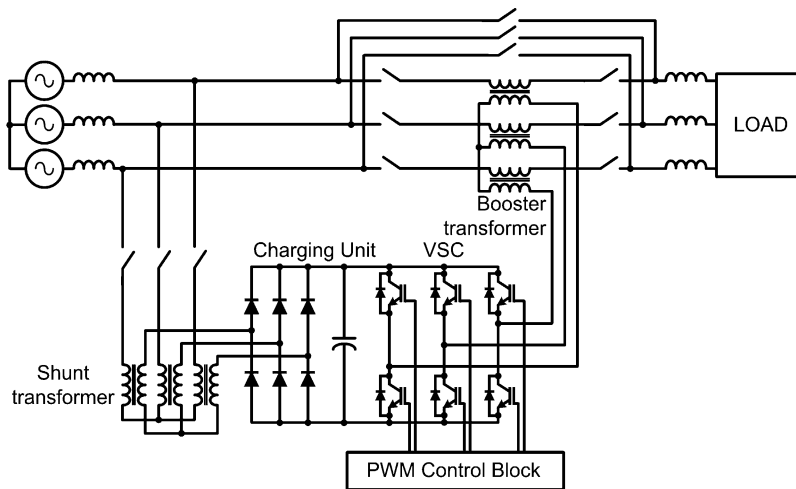

Fig. 24. DVR.

with the series capacitor, is that the voltage injected by an SSSC is not related to the line current and can be independently controlled. [28].

C. DVR

A DVR, shown in Fig. 24, is a device connected in series with the power system and is used to keep the load voltage constant, independently of the source voltage fluctuations [29]. When voltage sags or swells are present at the load terminals, the DVR responds by injecting three ac voltages in series with the incoming three-phase network voltages, compensating for the difference between faulted and pre-fault voltages. Each phase of the injected voltages can be controlled separately (i.e., their magnitude and angle). Active and reactive power required for generating these voltages are supplied by the VSC fed from a dc link, as shown in Fig. 24 [28]–[30]. In order to be able to mitigate voltage sag, the DVR must present a fast control response. The key components of the DVR are:

- switchgear;
- booster transformer;
- harmonic filter;
- IGCT VSC;
- dc charging unit;
- control and protection system;
- energy source, that is, a storage capacitor bank.

When power supply conditions remain normal, the DVR can operate in low-loss standby mode, with the converter side of the booster transformer shorted. Since no VSC modulation takes place, the DVR produces only conduction losses. Use of IGCT technology minimizes these losses.

SSSCs and DVRs can be integrated to get a system capable of controlling the power flow of a transmission line during steady state conditions and providing dynamic voltage compensation and short-circuit current limitation during system disturbances [30].

D. UPFC

The UPFC, shown in Fig. 25, consists of two switching converters operated from a common dc link provided by a

dc storage capacitor. One is connected in series with the line, and the other in parallel [28], [32]. This arrangement functions as an ideal ac to ac power converter in which the real power can freely flow in either direction between the ac terminals of the two inverters and each inverter can independently generate (or absorb) reactive power at its own ac output terminal. The series converter of the UPFC injects via series transformer, an ac voltage with controllable magnitude and phase angle in series with the transmission line. The shunt converter supplies or absorbs the real power demanded by the series converter through the common dc link. The inverter connected in series provides the main function of the UPFC by injecting an ac voltage V_{pq} with controllable magnitude ($0 \leq V_{pq} \leq V_{pqmax}$) and phase angle ρ ($0 \leq \rho \leq 360^\circ$), at the power frequency, in series with the line via a transformer. The transmission line current flows through the series voltage source, resulting in real and reactive power exchange between it and the ac system. The real power exchanged at the ac terminal that is the terminal of the coupling transformer is converted by the inverter into dc power, which appears at the dc link as positive or negative real power demand. The reactive power exchanged at the ac terminal is generated internally by the inverter.

The basic function of the inverter connected in parallel (inverter 1) is to supply or absorb the real power demanded by the inverter connected in series to the ac system (inverter 2), at the common dc link. Inverter 1 can also generate or absorb controllable reactive power, if it is desired, and thereby it can provide independent shunt reactive compensation for the line. It is important to note that whereas there is a closed “direct” path for the real power negotiated by the action of series voltage injection through inverter 1 and back to the line, the corresponding reactive power exchanged is supplied or absorbed locally by inverter 2, and therefore it does not flow through the line. Thus, inverter 1 can be operated at a unity power factor or be controlled to have a reactive power exchange with the line independently of the reactive power exchanged by inverter 2. This means that there is no continuous reactive power flow through the UPFC.

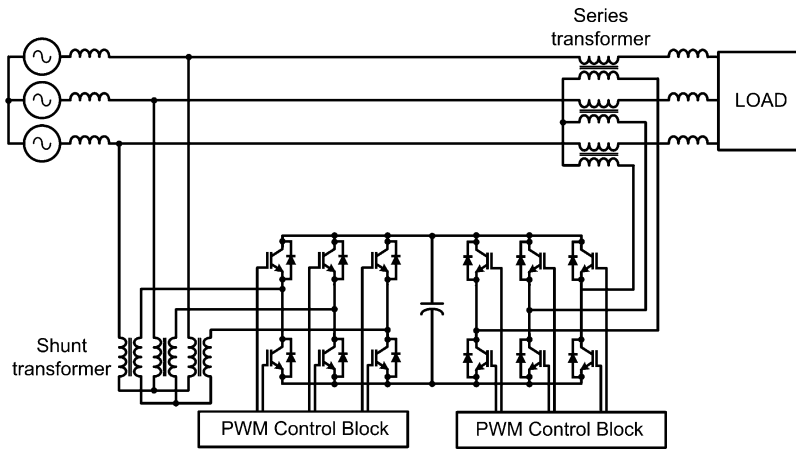

Fig. 25. UPFC power circuit topology.

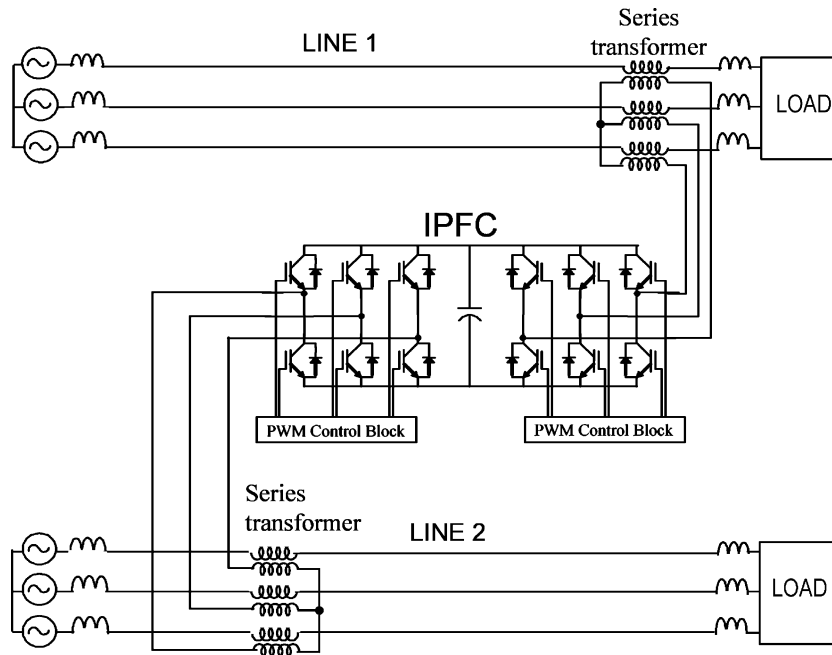

Fig. 26. IPFC power circuit topology.

E. IPFC

An IPFC, shown in Fig. 26, consists of two series VSCs whose dc capacitors are coupled, allowing active power to circulate between different power lines [33]. When operating below its rated capacity, the IPFC is in regulation mode, allowing the regulation of the P and Q flows on one line, and the P flow on the other line. In addition, the net active power generation by the two coupled VSCs is zero, neglecting power losses.

F. SMES

An SMES system, shown in Fig. 27, is a device for storing and instantaneously discharging large quantities of power [34], [35]. It stores energy in the magnetic field created by the flow of dc current in a coil of superconducting material that has been cryogenically cooled. These systems have been in use for several years to improve industrial power quality

and to provide a premium-quality service for individual customers vulnerable to voltage fluctuations. The SMES recharges within minutes and can repeat the charge/discharge sequence thousands of times without any degradation of the magnet. Recharge time can be accelerated to meet specific requirements, depending on system capacity. It is claimed that SMES is 97%–98% efficient and it is much better at providing reactive power on demand. Fig. 28 shows another SMES topology using three-level converters.

The first commercial application of SMES was in 1981 [36] along the 500-kV Pacific Intertie, which interconnects California and the Northwest. The device's purpose was to demonstrate the feasibility of SMES to improve transmission capacity by damping interarea modal oscillations. Since that time, many studies have been performed and prototypes developed for installing SMES to enhance transmission line capacity and performance. A major cost driver for SMES is the amount of stored energy. Previous studies have shown that

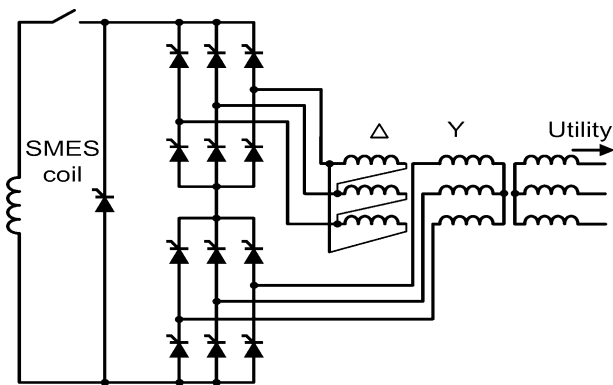

Fig. 27. SMES implemented with a thyristor converter.

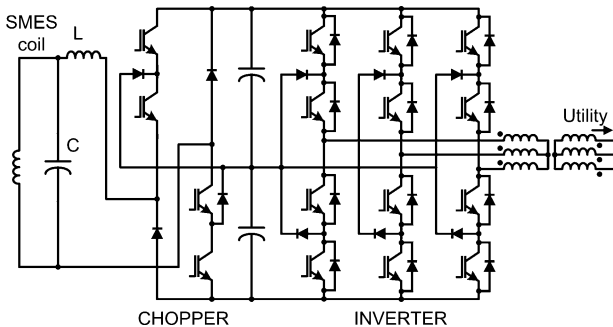

Fig. 28. SMES implemented with a three-level converter.

SMES can substantially increase transmission line capacity when utilities apply relatively small amounts of stored energy and a large power rating (greater than 50 MW).

Another interesting application of SMES for frequency stabilization is in combination with an SSSC [37].

G. Var Generation Using Coupling Transformers

The power industry is in constant search for the most economical way to transfer bulk power along a desired path. This can only be achieved through the independent control of active and reactive power flow in a transmission line. Traditional solutions, such as shunt or series inductor/capacitors and phase angle regulators, affect both the active and the reactive power flow in the transmission line simultaneously. With the use of a UPFC, which is based on a VSC, the active and the reactive power flow in the line can also independently be regulated. However, a new concept using proven transformer topologies is being investigated: the SEN transformer (ST) [38].

The ST, which is shown in Fig. 29, is a new family of controlled power flow transformers that meets the new requirements of independent active and reactive power flow control in a transmission line. Using state-of-the-art power flow control techniques, the ST redirects the active and reactive power from an overloaded line and offers effective power flow management. The main advantage of ST, compared with UPFC is its low cost, but the drawback of this alternative is its low dynamic response.

The series compensation, show as V_{COMP} in Fig. 29, is a series connection of the three phases of the secondary wind-

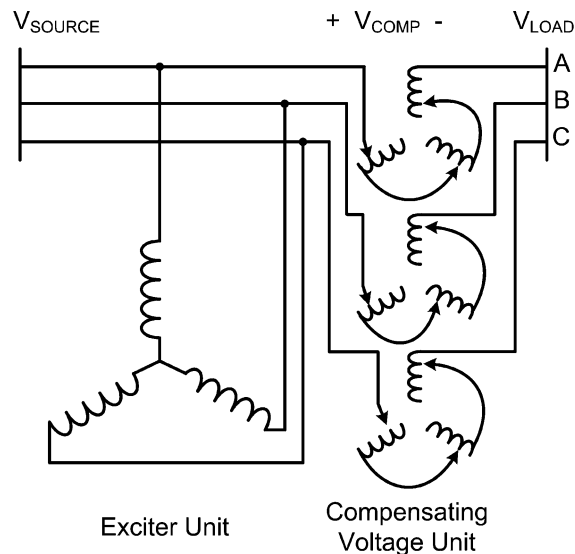

Fig. 29. ST.

ings of the transformer. This connection allows for independent control of voltage magnitude and phase shift in each one of the three phases.

VI. VAR COMPENSATOR'S APPLICATIONS

The implementation of high-performance reactive power compensators enable power grid owners to increase existing transmission network capacity while maintaining or improving the operating margins necessary for grid stability. As a result, more power can reach consumers with a minimum impact on the environment, after substantially shorter project implementation times, and at lower investment costs—all compared to the alternative of building new transmission lines or power generation facilities. Some of the examples of high-performance reactive power controllers that have been installed and are operating in power systems are described below. Some of these projects have been sponsored by the Electric Power Research Institute (EPRI), based on a research program implemented to develop and promote FACTS.

1) *Series Compensation in a 400-kV Transmission System in Sweden [24]:* The 420-kV transmission system between northern and central Sweden comprises eight lines with eight series capacitors, having a total rating of 4800 MVAR. The degree of compensation for the individual series capacitor banks has been selected in such a way that the sharing of active load (real power) between the individual 420-kV lines, which are of different designs, and the parallel connected 245-kV network became most favorable. In the optimum point, minimum losses for the total network are obtained. The reduction in losses, compared to the uncompensated case, has alone paid for the series capacitor investment in a few years. Another benefit of the series capacitors in the Swedish 420-kV network is the ability to supply reactive power and support the voltage during and after a large disturbance. Fig. 3 showed a typical compensated line with series capacitors.

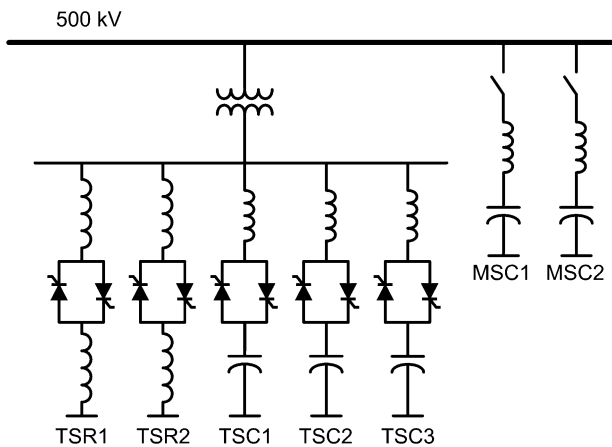

Fig. 30. SVC at the Forbes substation.

The selected degree of compensation is between 30% and 70% for the individual banks. With this compensation, stable transmission of more than 7000 MW on eight parallel lines is achieved. Without series compensation, five additional lines would have been needed to transmit the same amount of power. This, of course, would have been impermissible, not only from an investment point of view, but also with respect to the environmental impact, right of way problems, etc. The operating experience has been very good. The overall failure rate of capacitor units has been less than 0.1% per year. Other faults have also been insignificant and caused no interruption of service. A simple and reliable design of the protective and supervising system has contributed to this.

2) *500-kV Winnipeg–Minnesota Interconnection (Canada–USA) [24]*: Northern States Power Co. (NSP) of Minnesota is operating an SVC in its 500-kV power transmission network between Winnipeg, MB, Canada, and Minnesota. This device is located at Forbes substation in Minnesota and is shown in Fig. 30. The purpose is to increase the power interchange capability on existing transmission lines. This solution was chosen instead of building a new line as it was found superior with respect to increased advantage utilization as well as reduced environmental impact. With the SVC in operation, the power transmission capability was increased in about 200 MW.

The system has a dynamic range of 450 MVar inductive to 1000 MVar capacitive at 500 kV, making it one of the largest of its kind in the world. It consists of an SVC and two 500-kV, 300-MVar mechanically switched capacitor banks (MSCs). The large inductive capability of the SVC is required to control the overvoltage during loss of power from the incoming HVDC at the northern end of the 500-kV line.

The SVC consists of two TSRs and three TSCs. Additionally, the SVC has been designed to withstand brief (<200 ms) overvoltages up to 150% of rated voltage.

Without the SVC, power transmission capacity of the NSP network would be severely limited, either due to excessive voltage fluctuations following certain fault situations in the underlying 345-kV system, or to severe overvoltages at loss of feeding power from HVDC lines coming from Manitoba.

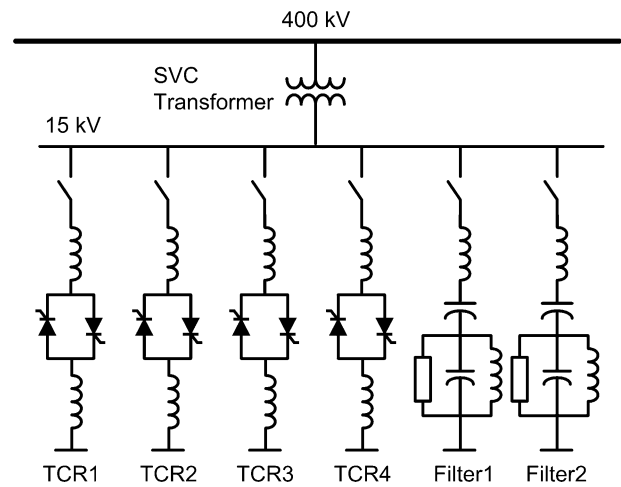

Fig. 31. SVC at the Auas substation.

3) *Namibia's Long Transmission Lines Give Rise to Unusual Resonance; A New SVC has Solved the Problem [40]*: Namibia is located in southwestern Africa, between Angola, Botswana, South Africa, and the Atlantic Ocean. While construction of the new 400-kV line has brought reliable power to Namibia, it was not without troubles. The line's length of 890 km, for instance, aggravated certain problems, mainly voltage instability and near 50-Hz resonance, which already existed in the NamPower system. To solve the problem, several solutions were considered as an answer to the resonance problem, including fixed and switched reactors, before deciding to install a FACTS device in the Auas substation. Finally, preference was given to conventional, proven SVC technology, which is shown in Fig. 31, provided by three TCRs, a fourth, continuously energized TCR, and two identical double-tuned filters, each rated at 40 MVar. The filters take care of harmonics and supply capacitive reactive power during steady-state operation.

The SVC has a dynamic range of 330 MVar (250 MVar inductive to 80 MVar capacitive) and is installed primarily to control the system voltage. High availability is essential for the SVC system. If, for any reason, it should have to be taken out of service, the 400-kV transmission system could not be operated without risking dangerous overvoltages. As a result, an availability figure of 99.7% was specified, and this strongly influenced the design, quality, functionality, and layout of its components and subsystems as well as of the SVC scheme as a whole.

The required capacitive MVar is provided by two 40-MVar filter banks. Each filter is double-tuned to the third/fifth harmonics and connected in an ungrounded configuration. The double-tuned design was chosen to ensure sufficient filtering even in the case of one filter becoming defective.

4) *Channel Tunnel Rail Link [41]*: Today, it is possible to travel between London, U.K., and Paris, France, in just over two hours, at a maximum speed of 300 km/h. The railway power system is designed for power loads in the range of 10 MW. The traction feeding system is a modern 50-Hz, 2–25-kV supply incorporating an autotransformer scheme to

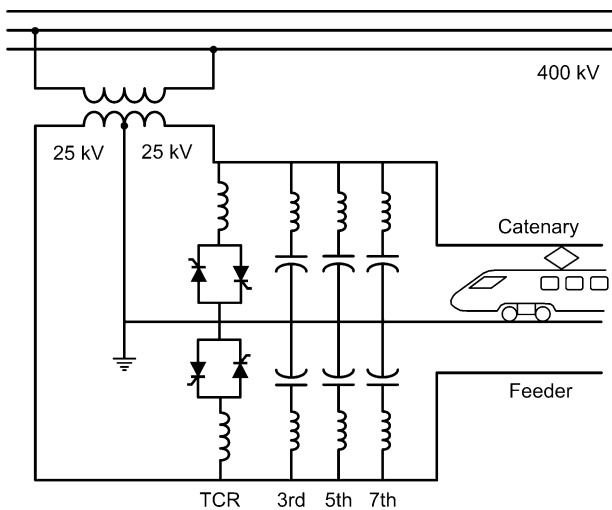

Fig. 32. Var compensation system for the channel tunnel.

keep the voltage drop along the traction lines low. Power step-down from the grid is direct, via transformers connected between two phases. A major feature of this power system, shown in Fig. 32, is the SVC support. The primary purpose of Var is to balance the unsymmetrical load and to support the railway voltage in the case of a feeder station trip—when two sections have to be fed from one station. The second purpose of the SVCs is to ensure a low tariff for the active power by maintaining unity power factor during normal operation. Thirdly, the SVCs alleviate harmonic pollution by filtering the harmonics from the traction load.

Harmonic compensation is important because strict limits apply to the traction system's contribution to the harmonic level at the supergrid connection points. The SVCs for voltage support only are connected on the traction side of the interconnecting power transformers. The supergrid transformers for the traction supply have two series-connected medium-voltage windings, each with its midpoint grounded. This results in two voltages, 180° apart, between the winding terminals and ground. The SVCs are connected across these windings; consequently, there are identical single-phase SVCs connected feeder to ground and catenary to ground. The traction load of up to 120 MW is connected between two phases. Without compensation, this would result in an approximately 2% negative phase sequence voltage. To counteract the unbalanced load, a load balancer (an asymmetrically controlled SVC) has been installed in the Sellindge substation. This has a three-phase connection to the grid. The load balancer transfers active power between the phases in order to create a balanced load (as seen by the supergrid).

5) *Static Compensator (STATCOM) "Voltage Controller" ± 100 -MVar STATCOM at Sullivan Substation (TVA) in Northeastern Tennessee [42]*: The Sullivan substation is supplied by a 500-kV bulk power network and by four 161-kV lines that are interconnected through a 1200-MVA transformer bank. Seven distributors and one large industrial customer are served from this substation. The STATCOM, shown in Fig. 33, is implemented with a 48 pulse, two-level

voltage-source inverter that combines 8 six pulse three-phase inverter bridges, each with a nominal rating of 12.5 MVA. The system also comprises a single step-down transformer having a wye and delta secondary to couple the inverter to the 161-kV transmission line and a central control system with operator interface. The STATCOM system is housed in one building that is a standard commercial design with metal walls and roof and measured 27.4×15.2 m.

The STATCOM regulates the 161-kV bus voltage during daily load increases to minimize the activation of the tap changing mechanism on the transformer bank, which interconnects the two power systems. The use of this Var compensator to regulate the bus voltage has resulted in the reduction of the use tap changer from about 250 times per month to 2–5 times per month. Tap changing mechanisms are prone to failure, and the estimated cost of each failure is about \$1 million. Without the STATCOM, the transmission company would be compelled either to install a second transformer bank or to construct a fifth 161-kV line into the area; both are costly alternatives.

6) *UPFC "All Transmission Parameters Controller": ± 160 -MVA Shunt and ± 160 -MVA Series at Inez Substation (AEP), Northeastern Virginia [42]*: The Inez load area has a power demand of approximately 2000 MW and is served by long and heavily loaded 138-kV transmission lines. This means that, during normal power delivery, there is a very small voltage stability margin for system contingencies. Single-contingency outages in the area will adversely affect the underlying 138-kV system and, in certain cases, a second contingency would be intolerable, resulting in a wide-area blackout. A reliable power supply to the Inez area requires effective voltage support and added real power supply facilities. System studies have identified a reinforcement plan that includes, among other things, the following system upgrades:

- 1) construction of a new double-circuit high-capacity 138-kV transmission line from Big Sandy to Inez substation;
- 2) installation of FACTS controller to provide dynamic voltage support at the Inez substation and to ensure full utilization of the new high-capacity transmission line.

The UPFC satisfies all these needs, providing independent dynamic control of transmission voltage as well as real and reactive power flow. The UPFC installation (see Fig. 34) comprises two identical three-phase 48-pulse, 160-MVA voltage-source inverters coupled to two sets of dc capacitor banks. The two inverters are interfaced with the ac system via two transformers, a set of magnetically coupled windings configured to construct a 48-pulse sinusoidal waveshape. With this arrangement, the following operation modes are possible. Inverter 1 (connected in parallel) can operate as a STATCOM, with either one of the two main shunt transformers, while inverter 2 (connected in series) operates as an SSSC. Alternatively, inverter 2 can be connected to the spare shunt transformer and operates as an additional STATCOM. With the latter configuration, a formidable shunt reactive capability of ± 320 MVA would be available, necessary for voltage support at some transmission contingencies in the

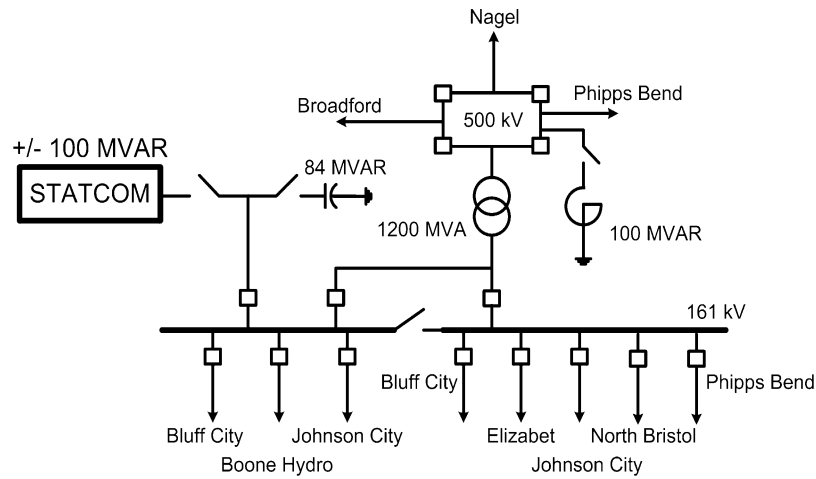

Fig. 33. 100-MVAR STATCOM at Sullivan substation.

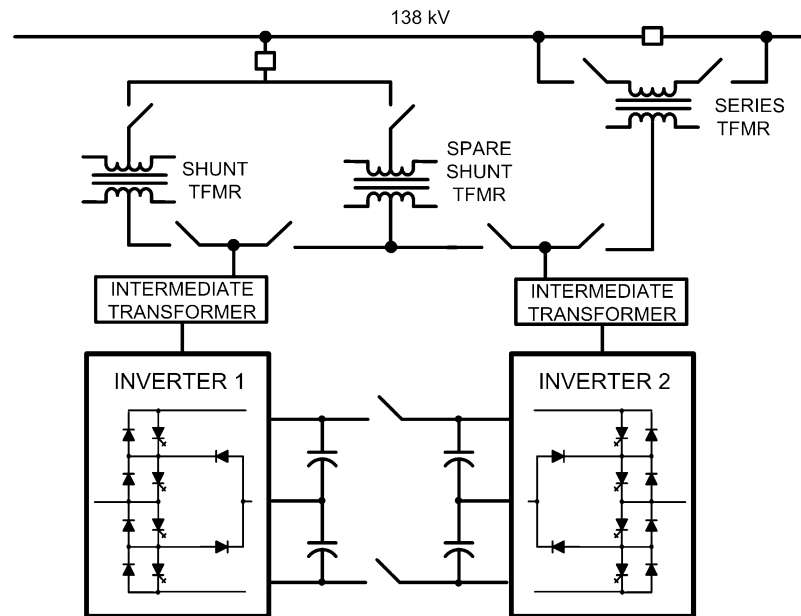

Fig. 34. Inverter pole assembly of UPFC at Inez substation.

Inez area. The expected benefits of the installed UPFC are the following.

- 1) Dynamic voltage support at the Inez substation to prevent voltage collapse under double transmission contingency conditions.
- 2) Flexible and independent control of real and reactive power flow on the new high-capacity (950-MVA thermal rating) of the 138-kV transmission line.
- 3) Reduction of real power losses by more than 24 MW, which is equivalent to a reduction of CO₂ emissions by about 85 000 tons per year.
- 4) More than 100 MW increase in the power transfer and excellent voltage support at the Inez bus.

7) *Convertible Static Compensator (CSC) in the New York 345-kV Transmission System [43]:* The CSC, a versatile and reconfigurable device based on FACTS technology, was designed, developed, tested, and commissioned in the New York 345-kV transmission system. The CSC, shown in Fig. 35, consists of two 100-MVA VSCs which can be reconfigured

and operated as either a STATCOM, an SSSC, a UPFC, or an IPFC. The CSC installation at the New York Power Authority's (NYPA's) Marcy 345-kV substation consists of a 200-MVA shunt transformer with two identical secondary windings, and two 100-MVA series coupling transformers for series devices in two 345-kV lines. The CSC provides voltage control on the 345-kV Marcy bus, improved power flow transfers, and superior power flow control on the two 345-kV lines leaving the Marcy substation: the Marcy–New Scotland line and Marcy–Coopers Corner line.

Each voltage-source inverter of Fig. 33 has 12 three-level NPC poles connected to a common dc bus. Inverter pole outputs are connected to an intermediate transformer, which synthesizes the three-phase near-sinusoidal 48-pulse voltage waveform that is coupled into the transmission system.

VII. CONCLUSION

An overview of the technological development of Var generators and compensators has been presented. Starting from

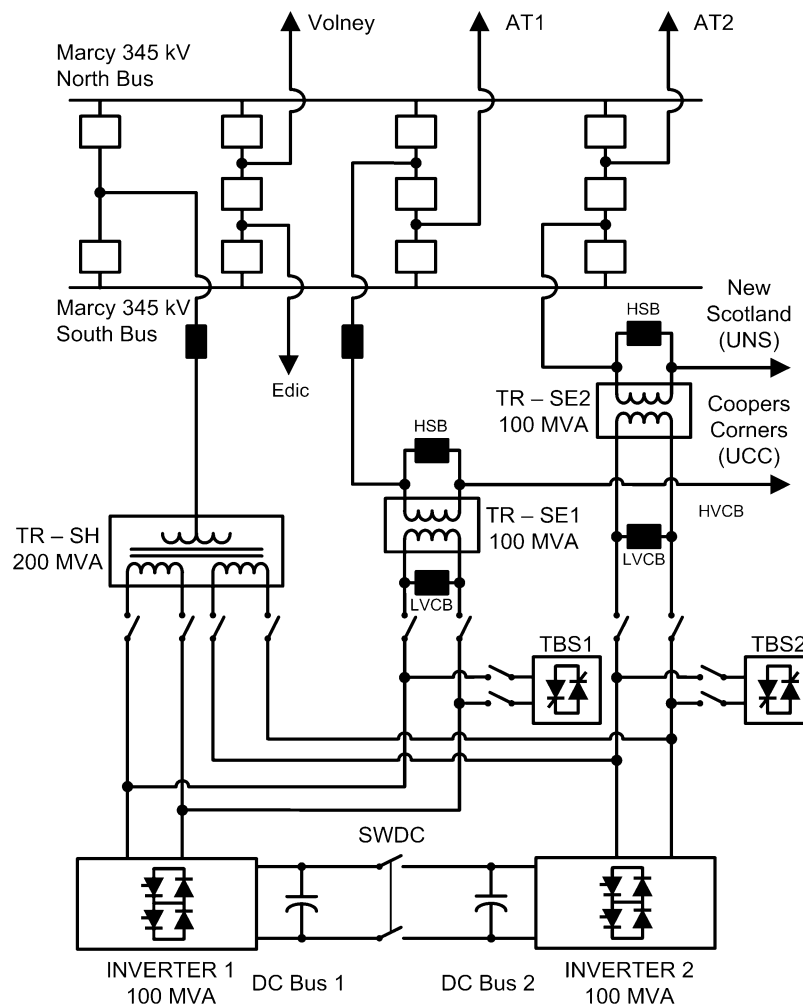

Fig. 35. One-line diagram of 2 × 100-MVA CSC.

the principles of Var compensation, classical solutions using phase-controlled semiconductors have been reviewed. The introduction of self-commutated topologies based on IGBTs and IGCTs semiconductors produced a dramatic improvement in the performance of Var compensators: they have a faster dynamic behavior and they can control more variables. The introduction of new self-commutated topologies at even higher voltage levels will increase the impact of Var compensation in future applications.

Some relevant examples of projects have been described, where it can be observed that modern Var compensators improve power systems performance, helping to increase reliability and the quality of power delivered to the customers. These examples show that Var compensators will be used on a much wider scale in the future as grid performance and reliability becomes an even more important factor. Having better grid controllability will allow utilities to reduce investment in the transmission lines themselves. The combination of modern control with real-time information and information technologies will move them very close to their physical limits. Besides, the development of faster and more powerful semiconductor valves will increase the applicability of Var generators to higher limits.

REFERENCES

- [1] T. J. Miller, *Reactive Power Control in Electric Systems*. New York: Wiley, 1982.
- [2] E. Wanner, R. Mathys, and M. Hausler, "Compensation systems for industry," *Brown Boveri Rev.*, vol. 70, pp. 330–340, Sep./Oct. 1983.
- [3] G. Bonnard, "The problems posed by electrical power supply to industrial installations," *Proc. IEE Part B*, vol. 132, pp. 335–340, Nov. 1985.
- [4] A. Hammad and B. Roesle, "New roles for static Var compensators in transmission systems," *Brown Boveri Rev.*, vol. 73, pp. 314–320, Jun. 1986.
- [5] N. Grudin and I. Roytelman, "Heading off emergencies in large electric grids," *IEEE Spectr.*, vol. 34, no. 4, pp. 43–47, Apr. 1997.
- [6] C. W. Taylor, "Improving grid behavior," *IEEE Spectr.*, vol. 36, no. 6, pp. 40–45, Jun. 1999.
- [7] Canadian Electrical Association, "Static compensators for reactive power control," 1984.
- [8] L. Gyugyi, "Reactive power generation and control by thyristor circuits," *IEEE Trans. Ind. Appl.*, vol. IA-15, no. 5, pp. 521–532, Sep./Oct. 1979.
- [9] L. Gyugyi, R. Otto, and T. Putman, "Principles and applications of static, thyristor-controlled shunt compensators," *IEEE Trans. Power App. Syst.*, vol. PAS-97, no. 5, pp. 1935–1945, Oct. 1980.
- [10] Y. Sumi, Y. Harumoto, T. Hasegawa, M. Yano, K. Ikeda, and T. Mansura, "New static Var control using force-commutated inverters," *IEEE Trans. Power App. Syst.*, vol. PAS-100, no. 9, pp. 4216–4223, Sep. 1981.
- [11] C. Edwards, K. Mattern, E. Stacey, P. Nannery, and J. Gubernick, "Advanced static Var generator employing GTO thyristors," *IEEE Trans. Power Del.*, vol. 3, no. 4, pp. 1622–1627, Oct. 1988.

- [12] L. Walker, "Force-commutated reactive power compensator," *IEEE Trans. Ind. Appl.*, vol. IA-22, no. 6, pp. 1091–1104, Nov./Dec. 1986.
- [13] K. E. Stahlkopf and M. R. Wilhelm, "Tighter controls for busier systems," *IEEE Spectr.*, vol. 34, no. 4, pp. 48–52, Apr. 1997.
- [14] R. Grünbaum, Å. Petersson, and B. Thorvaldsson, "FACTS, improving the performance of electrical grids," *ABB Rev.*, pp. 11–18, Mar. 2003.
- [15] N. Hingorani and L. Gyugyi, *Understanding FACTS, Concepts and Technology of Flexible ac Transmission Systems*. New York: IEEE Press, 2000.
- [16] H. Frank and S. Ivner, "Thyristor-controlled shunt compensation in power networks," *ASEA J.*, vol. 54, pp. 121–127, 1981.
- [17] H. Frank and B. Landstrom, "Power factor correction with thyristor-controlled capacitors," *ASEA J.*, vol. 45, no. 6, pp. 180–184, 1971.
- [18] J. W. Dixon, Y. del Valle, M. Orchard, M. Ortúzar, L. Morán, and C. Maffrand, "A full compensating system for general loads, based on a combination of thyristor binary compensator, and a PWM-IGBT active power filter," *IEEE Trans. Ind. Electron.*, vol. 50, no. 5, pp. 982–989, Oct. 2003.
- [19] L. Morán, P. Ziogas, and G. Joos, "Analysis and design of a synchronous solid-state Var compensator," *IEEE Trans. Ind. Appl.*, vol. IA-25, no. 4, pp. 598–608, Jul./Aug. 1989.
- [20] S. Torseng, "Shunt-connected reactors and capacitors controlled by thyristors," *IEE Proc. Part C*, vol. 128, no. 6, pp. 366–373, Nov. 1981.
- [21] A. K. Chakravorti and A. E. Emanuel, "A current regulated switched capacitor static volt ampere reactive compensator," *IEEE Trans. Ind. Appl.*, vol. 30, no. 4, pp. 986–997, Jul./Aug. 1994.
- [22] H. Jin, G. Goós, and L. Lopes, "An efficient switched-reactor-based static var compensator," *IEEE Trans. Ind. Appl.*, vol. 30, no. 4, pp. 997–1005, Jul./Aug. 1994.
- [23] J. W. Dixon, J. García, and L. Morán, "Control system for a three-phase active power filter which simultaneously compensates power factor and unbalanced loads," *IEEE Trans. Ind. Electron.*, vol. 42, no. 6, pp. 636–641, Dec. 1995.
- [24] R. Grünbaum, B. Halvarsson, and A. Wilk-wilczynski, "FACTS and HVDC light for power system interconnections," presented at the Power Delivery Conf., Madrid, Spain, 1999.
- [25] O. Gaupp, P. Zanini, P. Daehler, E. Baerlocher, R. Boeck, and J. Werninger, "Bremen's 100-MW static frequency link," *ABB Rev.*, vol. M420, no. 9, pp. 4–17, Oct. 1996.
- [26] J. Dixon and L. Morán, "A clean four-quadrant sinusoidal power rectifier, using multistage converters for subway applications," *IEEE Trans. Ind. Electron.*, vol. 52, no. 3, pp. 653–661, Jun. 2005.
- [27] L. Lorenz, "Power semiconductors: state of the art and future developments," in *Int. Power Electronics Conf., IPEC 2005 (Keynote Speech)* Niigata, Japan.
- [28] R. Grünbaum, M. Noroozian, and B. Thorvaldsson, "FACTS—powerful systems for flexible power transmission," *ABB Rev.*, pp. 4–17, May 1999.
- [29] N. H. Woodley, "Field experience with dynamic voltage restorer systems," presented at the IEEE Power Engineering Society Winter Meeting 2000, Singapore.
- [30] T. K. Saha and P. T. Nguyen, "Dynamic voltage restorer against balanced and unbalanced voltage sags: modeling and simulation," presented at the IEEE Power Engineering Society General Meeting, Denver, CO, 2004.
- [31] H. Okayama, T. Fujii, S. Tamai, S. Jochi, M. Takeda, R. Hellested, and G. Reed, "Application and development concepts for a new transformer-less FACTS device: the Multimode Static Series Compensator (MSSC)," presented at the Proc. IEEE PES Conf. Expo, Dallas, TX, 2003.
- [32] X. Wei, J. H. Chow, B. Fardanesh, and A.-A. Edris, "A common modeling framework of voltage-sourced converters for load flow, sensitivity, and dispatch analysis," *IEEE Trans. Power Syst.*, vol. 19, no. 2, pp. 934–941, May 2004.
- [33] —, "A dispatch strategy for an interline power flow controller operating at rated capacity," presented at the 2004 IEEE/PES Power Systems Conf. Exposition (PSC 2004), New York.
- [34] C. A. Luongo, "Superconducting storage systems: An overview," *IEEE Trans. Magn.*, vol. 32, no. 4, pp. 2214–2223, Jul. 1996.
- [35] M. J. Superczynski, "Analysis of the Power Conditioning System for a Superconducting Magnetic Energy Storage Unit," M.S. thesis, Virginia Polytechnic Inst. State Univ., Blacksburg, Aug. 2000.
- [36] Electric Power Research Institute, "Reassessment of superconducting magnetic energy storage (SMES) transmission system benefits," Rep. 01 006 795, Mar. 2002.
- [37] I. Ngamroo, "Robust frequency stabilization by coordinated superconducting magnetic energy storage with static synchronous series compensator," *Int. J. Emerging Elec. Power Syst.*, vol. 3, no. 1, Aug. 2005.
- [38] K. Sen, "Recent developments in electric power transmission technology" Apr. 15, 2003 [Online]. Available: http://wpweb2.tepper.cmu.edu/ceic/SeminarPDFs/Sen_CEIC_Seminar_4_15_03.pdf
- [39] A. Edris, "FACTS technology development: An update," *IEEE Power Eng. Rev.*, vol. 20, no. 3, pp. 4–9, Mar. 2000.
- [40] R. Grünbaum, M. Halonen, and S. Rudin, "Power factor, ABB static var compensator stabilizes Namibian grid voltage," *ABB Rev.*, pp. 43–48, Feb. 2003.
- [41] R. Grünbaum, Å. Petersson, and B. Thorvaldsson, "FACTS improving the performance of electrical grids," *ABB Rev. (Special Report on Power Technologies)*, pp. 13–18, 2003.
- [42] A. Edris, "Facts technology development: an update," *IEEE Power Engineering Rev.*, pp. 4–9, Mar. 2000.
- [43] S. Bhattacharya, B. Fardanesh, B. Shperling, and S. Zelingher, "Convertible static compensator: Voltage source converter based FACTS application in the New York 345 kV transmission system," in *Int. Power Electronics Conf. (IPEC 2005)* 2005, pp. 2286–2294.



Juan Dixon (Senior Member, IEEE) was born in Santiago, Chile. He received the Degree in electrical engineering from the Universidad de Chile, Santiago, in 1977 and the Ms. Eng. and Ph.D. degrees from McGill University, Montreal, QC, Canada, in 1986 and 1988, respectively.

In 1976, he was working with the State Transportation Company in charge of trolleybus operation. In 1977 and 1978, he worked at the Chilean Railways Company. Since 1979, he has been with the Electrical Engineering Department, Pontificia Universidad Católica de Chile, Santiago, where he is currently Professor. He has presented more than 70 works at international conferences and has published more than 30 papers related to power electronics in IEEE Transactions and IEE Proceedings. His main areas of interests are in electric traction, power converters, PWM rectifiers, active power filters, power factor compensators, and multilevel and multistage converters. He has done consulting work related to trolleybuses, traction substations, machine drives, hybrid electric vehicles, and electric railways. He has created an electric vehicle laboratory, where he has built state-of-the-art vehicles using brushless-dc machines with ultracapacitors and high specific energy batteries. Recently, he has started with research in distributed generation and power generation using renewable energy sources.



Luis Morán (Fellow, IEEE) was born in Concepción, Chile. He received the Degree in electrical engineering from the University of Concepción, Concepción, in 1982 and the Ph.D. degree from Concordia University, Montreal, QC, Canada, in 1990.

Since 1990, he has been with the Electrical Engineering Department, University of Concepción, where he is a Professor. He has written and published more than 30 papers on active power filters and static Var compensators in IEEE Transactions. He has extensive consulting experience in the mining industry, especially in the application of medium voltage ac drives, large power cycloconverter drives for SAG mills, and power quality issues. His main areas of interests are in ac drives, power quality, active power filters, FACTS, and power protection systems.

Dr. Morán received the City of Concepción Medal of Honor for achievement in applied research in 1998. From 1997 until 2001 he was Associate Editor of the IEEE TRANSACTIONS ON POWER ELECTRONICS. He is the principal author of the paper that received the IEEE Outstanding Paper Award from the Industrial Electronics Society for the best paper published in the IEEE TRANSACTIONS ON INDUSTRIAL ELECTRONICS during 1995 and was a coauthor of the paper that was awarded in 2002 by the IAS Static Power Converter Committee.



José Rodríguez (Senior Member, IEEE) received the Engineer degree in electrical engineering from the Universidad Técnica Federico Santa María, Valparaíso, Chile, in 1977 and the Dr.-Ing. degree in electrical engineering from the University of Erlangen, Erlangen, Germany, in 1985.

Since 1977, he has been with the Universidad Técnica Federico Santa María, where he is currently a Professor and Academic Vice-Rector. During his sabbatical leave in 1996, he was

responsible for the mining division of Siemens Corporation in Chile. He has several years' consulting experience in the mining industry, especially in the application of large drives such as cycloconverter-fed synchronous motors for SAG mills, high-power conveyors, controlled drives for shovels, and power quality issues. He has authored or coauthored more than 130 refereed journal and conference papers and contributed to one chapter in the *Power Electronics Handbook* (Academic, 2001). His research interests

are mainly in the areas of power electronics and electrical drives. In recent years, his main research interests are in multilevel inverters and new converter topologies.



Ricardo Domke was born in Concepción, Chile. He received the Degree in electrical engineering from the University of Concepción, Concepción, in 2000. He is currently working toward the M.Sc. degree from the University of Concepción.

He was Academic Collaborator in the Department of Electrical Engineering, University of Concepción, during 2004. His interests include reactive power compensation, active power filters, ac drives, and power distribution systems.